

BEST CM R290

Ceiling-mounted packaged unit for cold rooms

Instruction manual | v. 00
Instructions translated from the original

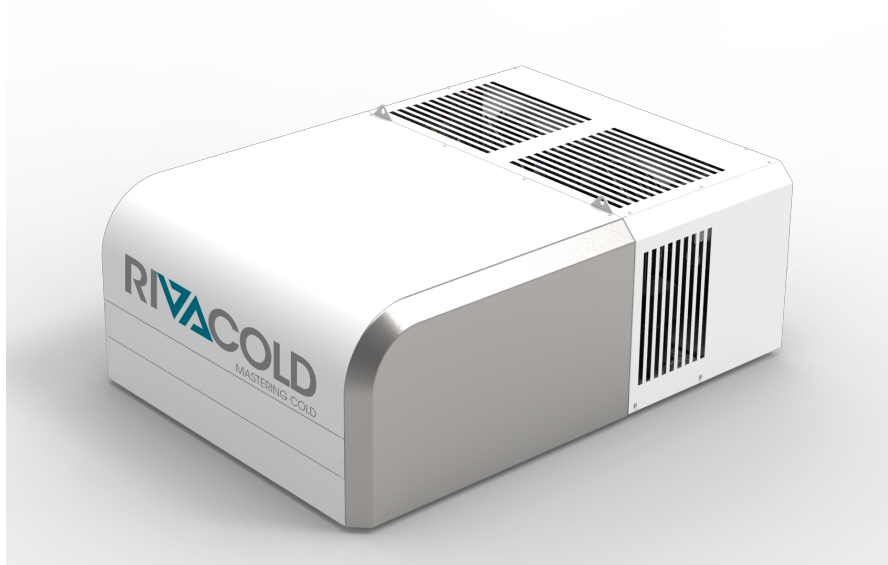

CE UK
CA



DANGER! Anyone who uses this machine is obliged to read these instructions for their own safety.

Ownership of information

Copyright © 2023, Rivacold srl

All rights reserved in all countries.

Any distribution, modification, translation or reproduction of parts or all the document is prohibited unless written authorisation is given by Rivacold srl with the exception of the following:

- Print the document in its original form, in whole or in part.
- Transfer the document to websites or other electronic systems.
- Copy the content unmodified and indicating Rivacold srl as the copyright holder.

Rivacold srl reserves the right to make changes or improvements to the relative documentation without prior notice.

Requests for authorisations, additional copies of this manual or technical information about it, must be addressed to:

Rivacold srl
Fraz. Montecchio - via Sicilia, 7
61022 Vallefoglia (PU)
Italy
info@rivacold.com
www.rivacold.com
+39 0721 919911

Contents

Warranty and assistance	1	7.7 System information	34
Conformity	1	7.8 Lock and unlock the control panel	35
1. Introduction	2	8. Parameters	36
1.1 Identification data	2	8.1 Structure of the parameters menu	36
1.2 Information about the instruction manual	2	8.2 Configuration parameters	37
2. Safety	3	8.3 Restore default parameters	39
2.1 General safety warnings	3	8.4 Service parameters	40
2.2 Personnel skills	4	8.5 Input/Output Parameters	40
2.3 Residual risks	4	8.6 Regulation parameters	41
2.4 Safety labels	5	8.7 Compressor parameters	42
2.5 Fixed guards	6	8.8 Condenser parameters	43
2.6 Noise	6	8.9 Defrost parameters	44
3. Learning about the packaged unit for cold rooms	7	8.10 Evaporator fan parameters	46
3.1 Limits of use	7	8.11 Electronic valve parameters	47
3.2 Overview	7	8.12 Electronic valve protections	49
3.3 Description of the packaged unit	7	8.13 Cold room light and door micro switch parameters	51
3.4 Packaged unit operation	8	8.14 Parameters of the alarms	51
4. Transport and handling	9	8.15 General function parameters	56
4.1 Handling warnings	9	8.16 General setting parameters	58
4.2 Transport and handling	10	9. Maintenance	62
5. Installation	11	9.1 Maintenance warnings	62
5.1 Installation warnings	11	9.2 Periodic maintenance	63
5.2 Setting the packaged unit in place	11	9.3 Corrective maintenance	63
5.3 Installation requirements	12	9.4 Checking or replacing condensing unit components	64
5.4 Install BEST CM	13	9.5 Remove the cover of the evaporating part	66
5.5 Secure the door micro switch	14	9.6 Checking or replacing evaporating part components	67
5.6 Connect the packaged unit to the electrical mains	15	9.7 Check or replace components of the electrical box	68
5.7 Work area and operational tasks	15	10. Diagnostics	70
6. Start-up	16	10.1 Installation and operation troubleshooting	70
6.1 Control panel	16	10.2 Errors indicated by the controller	72
6.2 Control panel operations	17	11. Appendix	86
6.3 Setting the date and time	18	11.1 Decommissioning	86
6.4 Using the MY I.D. App	22	11.2 Technical features	88
6.5 The passwords	25	11.3 Attachments	92
7. Quick menu	27	Conformity	92
7.1 Connecting to the micro USB port	27	11.4 Time zones	92
7.2 Description of the Quick menu	27		
7.3 View the input and output state	28		
7.4 Download and upload	31		
7.5 Alarm log	32		
7.6 HACCP alarm log	32		

Warranty and assistance

Warranty terms

RIVACOLD srl guarantees the product against any material or manufacturing defects for **one year from the registration date of the packaged unit (see "Register the packaged unit using the QR code" on page 23 or "Register the packaged unit using the numeric code" on page 24). Registration must take place within three months of the invoice date. If it is not registered, the date of issue of the sales invoice will apply.**

If defects in materials or workmanship are noted during this period, RIVACOLD srl will repair or replace the defective components under the terms and conditions set out below, with no charge for labour or spare parts.

The expenses to ship the packaged unit to the Customer Assistance Service are charged to the Customer.

Compensation will not be acknowledged for damage, of any kind, which the customer should be required to pay third parties for.

Note: *the warranty is only valid if the defects are claimed within the indicated time frames.*

Warranty exclusions

The following are excluded from the warranty:

- periodic maintenance operations
- damage resulting from improper use, including but not limited to:
 - incorrect power supply
 - using the product for purposes other than those intended
 - repairs carried out by unauthorised personnel or by the Customer himself
- defects resulting from modifications, adaptations or repairs made to the product by the Customer or by unauthorised personnel
- fortuitous and accidental events, such as falls and infiltration of liquids
- natural events and malicious or negligent actions

Post-warranty assistance

After the warranty time frames have elapsed, assistance will be provided by RIVACOLD srl with a charge for the replaced parts and labour and transport expenses in force at the time.

Warranty invalidation

The warranty is immediately invalidated if the model or serial number indicated on the product has been modified, deleted, removed or anyhow made illegible.

Assistance

Note: *for information on warranty terms, contact RIVACOLD srl.*

In case of a malfunction or fault or to find out about the terms of the warranty, the exclusions, the forfeiture of the warranty and how to apply the warranty and request

assistance, contact RIVACOLD srl or the dealer in the relevant zone.

Conformity

Declaration of conformity

Conformity 

Directives List of Directives for which the product is declared to be conforming:

- 2014/68/EU (Pressure Equipment Directive)
- 2014/35/EU (Low Voltage Directive)
- EMC 2014/30/EU (Electromagnetic Compatibility Directive)
- 2006/42/EC (Machinery Directive)
- RED 2014/53/EU (Radio Equipment Directive)

Conformity 

Directives List of Directives for which the product is declared to be conforming:

- UK S.I. 2016 No. 1105 Pressure Equipment (Safety) Regulations
- UK S.I. 2016 No. 1101 Electrical Equipment (Safety) Regulations
- UK S.I. 2016 No. 1091 Electromagnetic Compatibility Regulations
- UK S.I. 2008 No. 1597 Supply of Machinery (Safety) Regulations
- UK S.I. 2017 No. 1206 Radio Equipment Regulations

Note: *the original declaration of conformity accompanies the machine.*

1. Introduction

This section includes the following topics:

- 1.1 Identification data 2
- 1.2 Information about the instruction manual 2

1.1 Identification data

1.1.1 Manufacturer's contacts

RIVACOLD srl
 Fraz. Montecchio - via Sicilia, 7
 61022 Vallefoglia (PU)
 Italy
 Tel: +39 0721 919911
 Fax: +39 0721 490015
 e-mail: info@rivacold.com

1.1.2 Identification

The information on the identification plates is important for requesting assistance, maintenance or spare parts.

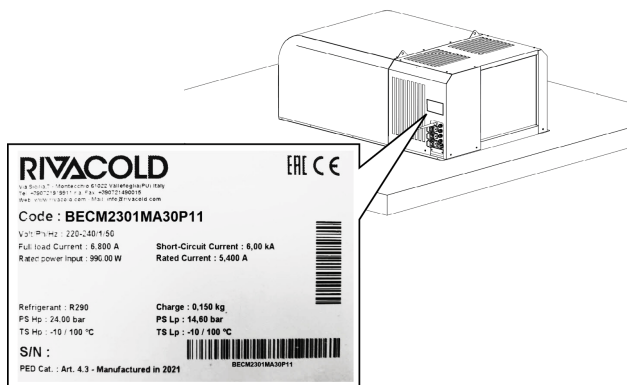

1.1.3 Code legend

BE	Range. BE : BEST
C	C Ceiling Mounted
130/ 230/ 235	Housing/frame dimensions. 130 : for one condensing unit fan with 300 diameter, 230 : for two condensing unit fans with 300 diameter, 235 : for two condensing unit fans with 350 diameter
1/ 2 / 3	Number of compressors
M/L/V	Application. M : medium temperature, L : low temperature, V : variable speed
A/W	Type of condensation. A : air W : water
05 - 90	Progressive number that identifies the different power outputs
P	Refrigerant gas. P : R290
1/ 2	Laminating part. 1 : mechanical thermostat, 2 : electronic thermostat
1/ 2	Voltage. 1 : one-phase, 2 : three-phase
00	Sequential number for optionals

1.2 Information about the instruction manual

1.2.1 Objectives of the instruction manual

These instructions guide the personnel in charge of installing, using and servicing the packaged unit safely.

1.2.2 Obligations with respect to this instruction manual

NOTICE: This instruction manual is an integral part of the packaged unit and must be kept for its entire life cycle.

It must be stored in a clean place and kept in good condition to be accessible to the operators. If the manual is lost or damaged, contact RIVACOLD srl.

If the packaged unit is sold, always attach the instruction manual.

1.2.3 Data of the instruction manual

Packaged unit: BEST CM R290

Title: Instruction manual

Code: 9600-0095

Month and year of publication: 04-2023

Type of manual: translation of original instructions

1.2.4 Safety messages

Below are the warnings related to user safety and damage to the machine provided in this document:

DANGER!

indicates a hazardous situation which, if not avoided, will result in death or serious injury.

WARNING

Indicates a hazardous situation which, if not avoided, can result in death or serious injury.

CAUTION

Indicates a hazardous situation which, if not avoided, can result in slight injury.

NOTICE

Indicates obligations which, if not complied with, can damage the device.

1.2.5 Other messages

Note: neutral and positive information that emphasizes or adds information to the main text. It provides information that can only be applied in special cases.

1.2.6 Figures and illustrations

The figures and illustrations in this instruction manual are only used for reference and may differ in detail and proportions from the actual product.

1.2.7 Updates of the instruction manual

Code	Publication date	Updates
9600-0095	04-2023	First publication

1.2.8 Documentation provided

Manual	Recipients	Code	Date
Instruction manual (this manual)	The personnel indicated in "Personnel skills" on the next page.	9600-0095 . 04-2023	04-2023
Installation Manual		9600-0134	
Electrical diagram		-	-
IoT Activation Instructions (optional)		9600-0073	2022

2. Safety

This section includes the following topics:

2.1 General safety warnings	3
2.2 Personnel skills	4
2.3 Residual risks	4
2.4 Safety labels	5
2.5 Fixed guards	6
2.6 Noise	6

2.1 General safety warnings

2.1.1 Obligations for the employer

The employer must select, train and appoint authorised personnel to carry out their duties.

It is the employer's responsibility to instruct the personnel in charge and to enforce the safety regulations for every specific task. The employer must also define the operating procedures and ensure that they comply with the instruction manual provided by the manufacturer. See "Personnel skills" on the next page for more information.

2.1.2 Obligations for the recipients of the instruction manual

 **NOTICE:** anyone who uses this packaged unit is obliged to read this instruction manual for their own safety.









2.1.3 Recipients of this instruction manual



This instruction manual is intended for personnel authorised by the employer to install, use and service the packaged unit.

2.1.4 Clothing

 Do not wear loose clothing, ties, chains and watches that can get caught in the moving parts.

2.1.5 Personal protective equipment

Equipment	Stage
 	During lifting and transport
 	
 	During installation and commissioning
 	

Equipment	Stage
	During use
	During maintenance or dismantling

2.2 Personnel skills



2.2.1 Preamble



Every section of this instruction manual is preceded by the skills that the personnel in question must have. Not having these skills can:

- endanger the safety of personnel
- invalidate the warranty

Note: the operator's tasks are defined by the complexity of the operations and their level of experience and skill. Operators must collaborate with the technicians to receive operating instructions or to request adjustment operations.

2.2.2 List of skills

Symbol	Operations allowed	Skills
 COMPANY Manufacturer's personnel	All operations	Technical personnel employed or authorised by the manufacturer.
 Mechanical maintenance engineer	<ul style="list-style-type: none"> • Installation and decommissioning • Maintenance excluding works on the electrical system • Solving problems that cause blockages 	Has extensive technical knowledge in the mechanical and pneumatic fields. Understands the technical drawings and the refrigerating diagram.

Symbol	Operations allowed	Skills
 Electrical maintenance engineer	<ul style="list-style-type: none"> • Electrical connections during installation and decommissioning • Solving problems that cause faults in the electrical system 	Has extensive technical knowledge in the electrical field. Understands the wiring diagrams and works inside electrical boxes, junction boxes and control equipment in the presence of voltage. Understands the refrigerating diagram.
 Operator	<ul style="list-style-type: none"> • Operate using the commands • Clean the packaged unit • Adjust the equipment after receiving the relevant instructions • Change certain parameters but only after receiving the relevant instructions 	Has general technical knowledge and experience in managing the packaged unit.
 Driver	Lifting and handling	Authorised to use means to lift and handle materials and equipment according to the laws in force in the country of installation.

2.3 Residual risks

2.3.1 Definition

A danger zone is any area inside or outside the packaged unit where a person is exposed to the risk of serious or minor injuries.

Every procedure described in this instruction manual indicates the possible risks. Always follow the instructions in the instruction manual to avoid damage or injury.

- Follow the warnings given in this instruction manual concerning installation.
- Follow the instructions for adjustment, cleaning and maintenance given in this instruction manual.

2.3.2 Preamble

The packaged unit has been designed and built to function, be adjusted and subjected to maintenance without these operations exposing the personnel in charge to risks if carried out according to the instructions given in this instruction manual. The adopted measures minimise the risk of accidents throughout the life cycle of the packaged unit, both in the context of the intended use and of reasonably foreseeable misuse.

2.3.3 Mechanical residual risks

Risk	When it occurs	How to avoid it
Bruising and superficial abrasion	During installation, cleaning, maintenance and dismantling.	Wear the personal protective equipment.
Crushing	During transportation, lifting, installation and dismantling.	<ul style="list-style-type: none"> Always use lifting equipment and accessories of adequate capacity for the load to be lifted. Prevent unauthorised people from accessing the area near the packaged unit. Follow the warnings given in this instruction manual concerning lifting. Check that the wall where the packaged unit is installed is suitable for supporting the packaged unit.
Falling from above	During installation, maintenance at a height and dismantling.	Always use adequate means and accessories.
Impact	During installation, cleaning and maintenance.	Wear the personal protective equipment.
High pressure fluid ejection	During maintenance and dismantling.	Maintenance on pressurised circuits must only be performed by the mechanical maintenance engineer.
Contact with moving and sharp parts	During maintenance.	<ul style="list-style-type: none"> Wear the personal protective equipment. Isolate the packaged unit from the power supply.

2.3.4 Electrical residual risks

Risk	When it occurs	How to avoid it
Electrocution	During installation, connection, maintenance and dismantling.	<ul style="list-style-type: none"> The electrical connection and disconnection must only be carried out by the electrical maintenance engineer. Wear the personal protective equipment.

2.3.5 Thermal residual risks

Risk	When it occurs	How to avoid it
Low temperatures	During maintenance in the cold room.	<ul style="list-style-type: none"> Wear the personal protective equipment. Follow the instructions for adjustment, cleaning and maintenance given in this instruction manual. Take work breaks to prevent long exposure to excessively low temperatures.
Burns	During and immediately after use.	Wear the personal protective equipment.

2.3.6 Chemical residual risks

Risk	When it occurs	How to avoid it
Explosion and fire	During transport and handling, installation, cleaning and maintenance.	Follow the regulations in force and the warnings on adjustments and maintenance given in this instruction manual.
Burns	During transport and handling, installation, cleaning and maintenance.	Follow the regulations in force and the warnings on adjustments and maintenance given in this instruction manual.

2.4 Safety labels

2.4.1 General warnings

Clean the labels if dirty and replace them if detached or damaged.

DO NOT apply other labels or notes that can hide the indications affixed by the manufacturer or make them partially illegible.

2.4.2 Position of the safety stickers

The position of the stickers is as follows:

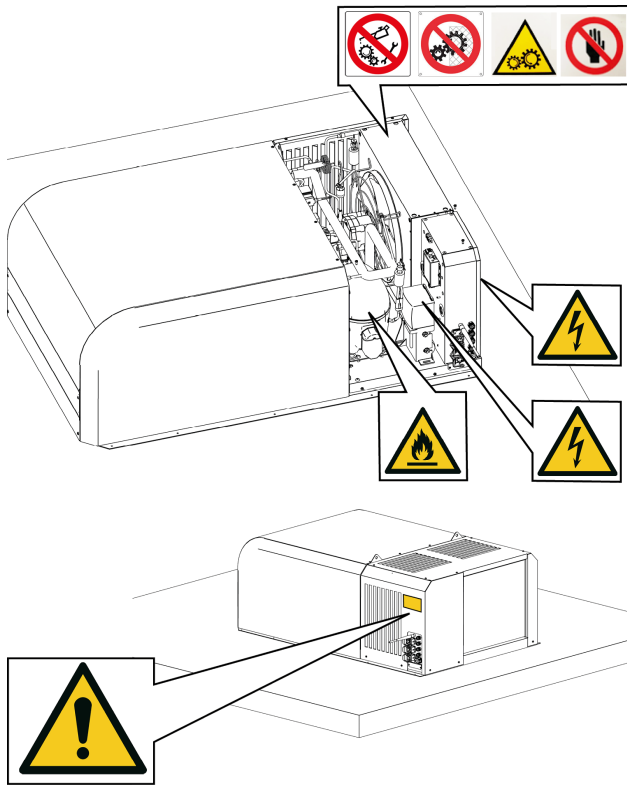

Symbol	Description
	Do not repair moving parts
	Do not remove safety devices
	Do not clean the condenser by hand
	Moving parts
	Flammable gas
	Electrocution
	Disconnect the power supply before performing maintenance

2.5 Fixed guards

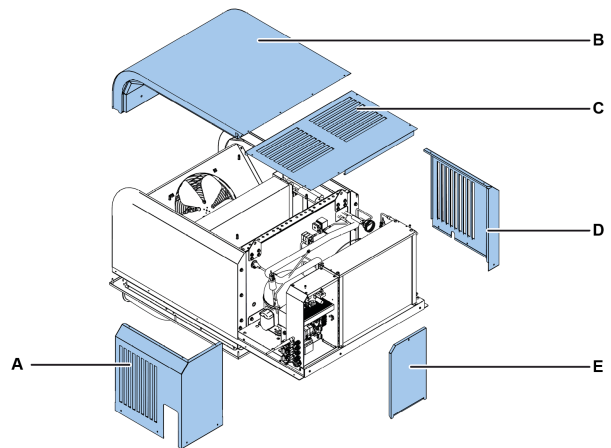

Part	Description
A	Left side panel
B	Evaporating part cover
C	Top panel
D	Right side panel
E	Electrical box panel

2.6 Noise

2.6.1 Sound pressure level

The sound pressure measured while the packaged unit is running is less than 70 dB(A) LEX and/or 135 dB(C) Lpeak.

3. Learning about the packaged unit for cold rooms

This section includes the following topics:

3.1 Limits of use	7
3.2 Overview	7
3.3 Description of the packaged unit	7
3.4 Packaged unit operation	8

3.1 Limits of use

3.1.1 Intended use

BEST CM R290 is an indoor ceiling-mounted packaged unit for cold room refrigeration. It is available with air- and water-cooled condensation.

3.1.2 Unintended use

This packaged unit has been designed for all the uses declared in "Intended use" above.

In particular, with this packaged unit it is NOT possible to:

- Install the packaged unit on a ceiling with different structural characteristics than those intended
- Install the packaged unit in a cold room with different characteristics from those intended
- Use a different refrigerant gas than that intended
- Use the packaged unit without the protections
- Apply labels or notes that can hide the indications provided with the packaged unit or make them partially illegible
- Tamper with the electrical equipment and/or safety devices
- Set the packaged unit with different values than those indicated by the manufacturer
- Climb on or cling to the packaged unit

3.1.3 Work environment

The packaged unit CANNOT be used in the following conditions:

- Environments with a potentially explosive atmosphere (ATEX)
- Environments with vapours deriving from chemical processes
- Environments with the presence of radiation (ionizing and non)
- Environments with temperatures outside of the +5°C to +43°C range
- With water temperatures outside the range of +5°C to +48°C in the case of the water-cooled version
- Environments subject to potential fire hazards (see the local standards and regulations applied at national level)
- Environments with poor ventilation
- Outdoors (installation), exposed to the atmospheric agents

3.2 Overview

3.2.1 Packaged unit configurations

The packaged unit is available in different configurations depending on the refrigeration temperature range:

- NT (normal temperature): $-5\text{ °C} \leq T_{\text{cold room}} \leq +15\text{ °C}$
- LT (low temperature): $-25\text{ °C} \leq T_{\text{cold room}} \leq -5\text{ °C}$

3.2.2 Circuits of the packaged unit

Depending on the model, the packaged unit can be single-circuit, dual-circuit or three-circuit. The circuits are totally independent of each other. Every circuit is a compact and hermetically sealed system in accordance with the definitions set forth in UNI EN 378-1. The amount of refrigerant for every circuit is $\leq 150\text{ g}$ to allow installation to take place anywhere without restrictions, as required by the reference standard.

Note: RIVACOLD srl cannot be held liable for any restrictions due to national or regional regulations or laws.

3.2.3 Optional extras

Cataphoresis coils

3.3 Description of the packaged unit

3.3.1 BEST CM components

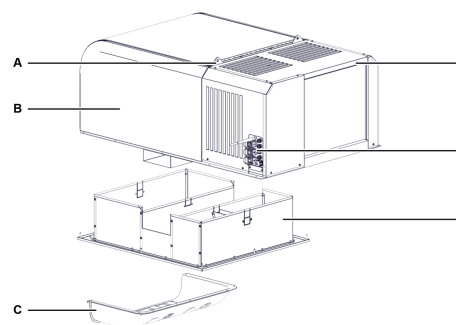

Part	Description
A	Eyebolts
B	Evaporating part
C	Air conveyor
D	Condensing unit part
E	Electrical connections
F	Air ducting

3.3.2 Internal Components

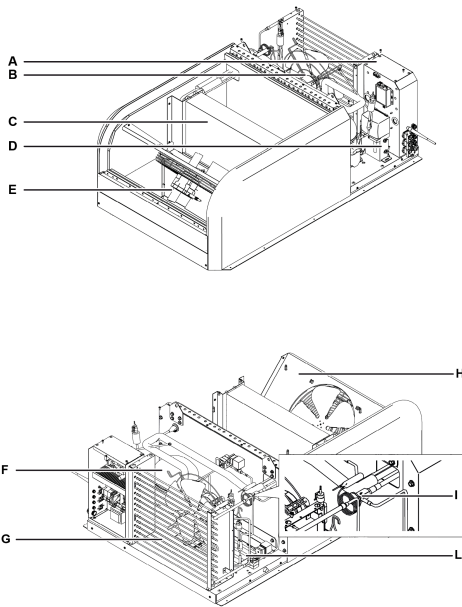

Part	Description
A	Electrical box
B	Condensing unit ventilation unit
C	Evaporator
D	Compressor electrical box
E	Ventilation unit of the evaporating part
F	Compressor
G	Condenser
H	Evaporator tray
I	Thermostatic valve
L	Condensate drain tray

3.3.3 Connections

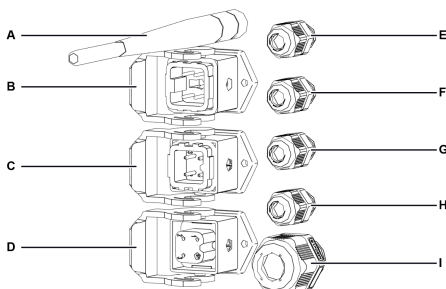

Part	Description
A	IoT Gateway Antenna
B	Master-slave
C	Alarm
D	Door heater (only for low temperature)
E	Remote control panel
F	Door micro switch

Part	Description
G	BMS (Building Management System)
H	Cold room light
I	Power supply

3.3.4 USB port connection

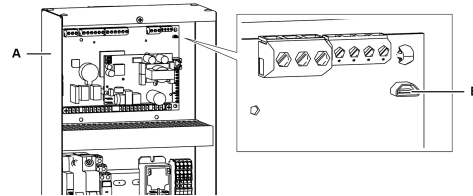

Part	Description
A	Electrical box
B	USB micro port

3.3.5 Door micro switch components

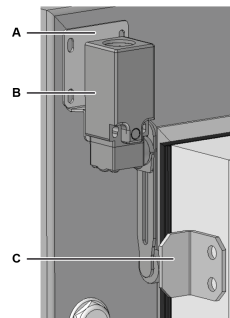

Part	Description
A	Fixing plate
B	Door micro switch
C	Retainer

3.4 Packaged unit operation

3.4.1 General operation

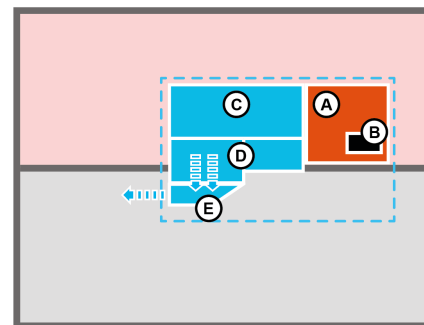

The packaged unit is a refrigerating unit composed of a condensing part [A], a controller [B] and an evaporating part [C] located above the ceiling of the cold room and an air ducting system [D] and an air conveyor [E] applied to the ceiling inside the cold room. The

controller manages the refrigeration and defrost cycles.

The refrigeration cycle is the compression type and the refrigerant gas is condensed and evaporated cyclically.

Defrosting is of the hot gas type and takes place automatically with a cyclic frequency that can be modified by the user or fully automatically via the Smart Defrost function already active in the standard configuration.

3.4.2 Operation of the MY I.D. App

Within the App you can access the following sections:

- **News:** to know the news and events of the Rivacold world.
- **Select:** to know all the Rivacold products.
- **Documents:** to download the sales and technical documentation relating to Rivacold products.
- **My Vision:** to have access to the cloud through which it is possible to monitor and control the operation of every packaged unit. The IOT service must be purchased to have access to this area
- **Smart Control:** to control and command the packaged unit using the mobile device connected via Bluetooth, instead of the interface on the machine.
- **Contacts:** to know and find the closest Rivacold sales contact person.

4. Transport and handling

This section includes the following topics:

4.1 Handling warnings	9
4.2 Transport and handling	10

4.1 Handling warnings

4.1.1 Required skills



4.1.2 Safety



DANGER!

Explosion/Burn. Presence of flammable gas. During transport and handling, adopt all the precautions required by the legislation in force.



WARNING

Crushing. Always use lifting equipment and accessories of adequate capacity for the load to be lifted. Use the personal protective equipment. Follow the warnings given in this instruction manual concerning lifting.

NOTICE

There is oil in the machine. Always handle in an upright position.

4.1.3 Choosing lifting equipment and accessories

The following general indications apply to load lifting operations and also concern the use of lifting accessories not supplied with the packaged unit.

Choose lifting equipment and accessories according to the dimensions, weight and shape of the load to be lifted.

4.1.4 Preliminary checks

- Check that the lifting accessories are intact.
- Check that there are no people or objects in the manoeuvring area.
- Check the stability and correct balancing of the load by slowly lifting it slightly.

4.1.5 General warnings

- Due to the presence of oil in the compressor, move the packaged unit while still maintaining the upright position. NEVER overturn the packaged unit.
- Choose the harnessing points so that the load is balanced correctly, considering its centre of gravity.
- Monitor the lifting movement from a safe distance. NEVER stand under the load.
- Only guide the load with ropes and hooks.
- If you need to accompany the load with your hands, pull the load. DO NOT push it.
- Lift the load continuously, without jerking or sudden movements.
- After placing the load on the ground, slacken the tension on the tie rods before removing the lifting accessories.

4.1.6 Lifting angle

The angle between the tie rods changes the applied load according to the following diagram:

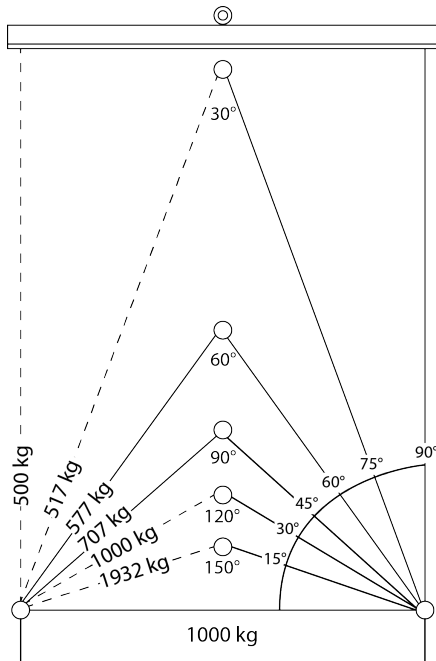

Note: we recommend using angles less than 60°.

- fastening kit
- cold room light

4.2.3 Storage

The packed packaged unit must be stored indoors or covered to avoid exposure to atmospheric agents.

4.2.4 Lifting the packaged unit

Use the lifting eyebolts [A] on the frame.

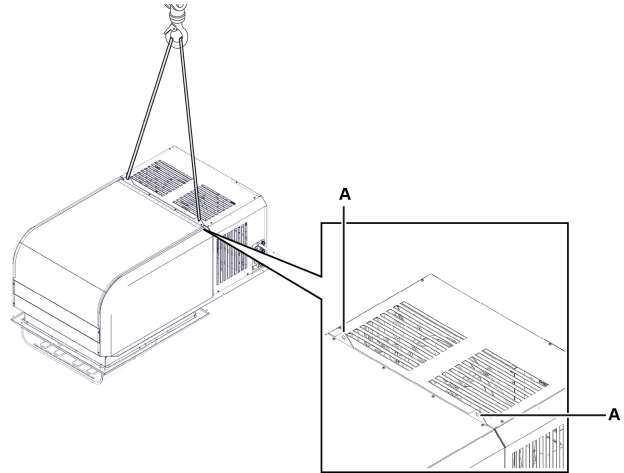

4.2 Transport and handling

4.2.1 Transport conditions

The packaged unit is secured and packed in such a way as to prevent movement, impact and damage during transport.

4.2.2 Packaging content

The packaged unit is placed in a single package, complete with all electrical connections. The contents of the packaging are as follows:

- packaged unit
- air ducting
- air conveyor
- door micro switch with retainer

5. Installation

This section includes the following topics:

5.1 Installation warnings	11
5.2 Setting the packaged unit in place	11
5.3 Installation requirements	12
5.4 Install BEST CM	13
5.5 Secure the door micro switch	14
5.6 Connect the packaged unit to the electrical mains	15
5.7 Work area and operational tasks	15

5.1 Installation warnings

5.1.1 Preamble

Always refer to the information provided when ordering the packaged unit. Contact Rivacold technical assistance to receive specific information for the installation.

5.1.2 Required skills



COMPANY

5.1.3 Safety



⚠ DANGER!

Explosion/Burn. Presence of flammable gas. The place of installation must have good air circulation and must be far from heat sources, such as naked flames or hot surfaces and from electrical components or flammable materials. During installation, adopt all the precautions required by legislation in force.

Crushing. Always use lifting equipment and accessories of adequate capacity for the load to be lifted and follow the lifting warnings given in this instruction manual.

Falling from above. Always use adequate means and accessories. Provide safe access to the installation area. Follow the warnings given in this instruction manual.

Electrocution. Always use adequate means and accessories. Follow the warnings given in this instruction manual.

5.2 Setting the packaged unit in place

5.2.1 Characteristics of the placement area

NOTICE

The packaged unit must only be installed inside rooms that fully shelter it.

The placement area must have the following characteristics:

- The place of installation must have good air circulation and must be far from heat sources (e.g. naked flames or hot surfaces) and from electrical components or flammable materials.
- The ceiling must have an adequate surface to support the weight of the packaged unit, regular, well levelled and free of vibrations.
- The ceiling must have a minimum thickness of 80 mm and a maximum of 200 mm.
- The place of installation must have a temperature indicated in "Technical features" on page 88.

5.2.2 Minimum distances of the placement area

The packaged unit must be positioned in a placement area with minimum distances (in millimetres in the image) to allow proper air circulation and facilitate maintenance.

Position the packaged unit with the air conveyor aperture facing the far wall.

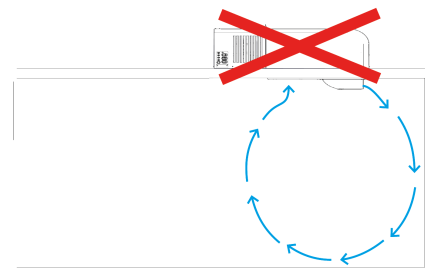
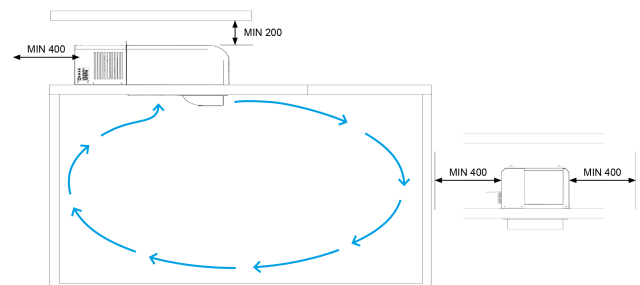

5.2.3 Removing the packaging

NOTICE

Environmental contamination. Follow the regulations in force regarding the disposal of polluting materials.

Remove all packaging and fastening elements used during transport.

5.2.4 Inspections and checks on the packaged unit

Visually inspect the packaged unit to look for any damage caused during transport that could compromise normal operation. Transport damage must be attributed to the carrier and immediately reported to RIVACOLD srl.

5.2.5 Storage

If the packaged unit must be stored for long periods, for example waiting to be relocated, follow the instructions below.

- Isolate the packaged unit from energy sources.
- Clean the packaged unit and all its components.
- Position the packaged unit so that there is sufficient space to pick it up, lift it and move it safely.
- Place the packaged unit indoors and covered with sheets so as to avoid exposure to atmospheric agents.
- Place the packaged unit on a stable, solid supporting surface with characteristics so as to withstand the weight of the packaged unit and the equipment involved
- Place the packaged unit in an environment with specific temperature and humidity conditions

See "Technical features" on page 88 for more information.

5.3 Installation requirements

5.3.1 Stability requirements

Check that the ceiling where the packaged unit is to be installed is suitable for supporting it.

5.3.2 Requirements for the connection to the electrical mains

The packaged unit is supplied with a power lead and plug.

Comply with the following requirements:

- The voltage and frequency supplied must correspond to those indicated on the identification plate
- Insert a differential circuit breaker (RCD) between the power line and the packaged unit, adequately sized for the application and the laws in force in the country of installation. The switch must be near the packaged unit.

See "Technical features" on page 88.

5.4 Install BEST CM

5.4.1 Dimensions of the window to be made in the ceiling

Depending on the size of the packaged unit, a window with the following dimensions (in millimetres) should be cut in the cold room ceiling. Use the packaging template to proceed more quickly.

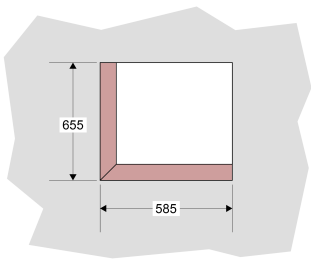
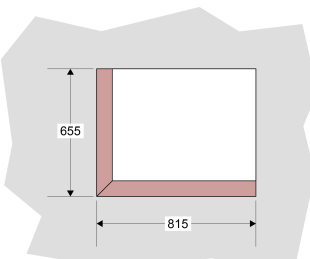
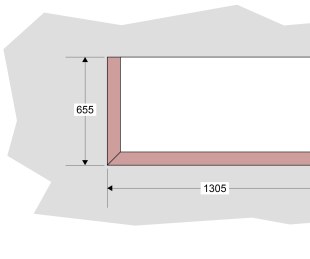
BEC130 codes	BEC230 codes	BEC235 codes
		

5.4.2 Procedure

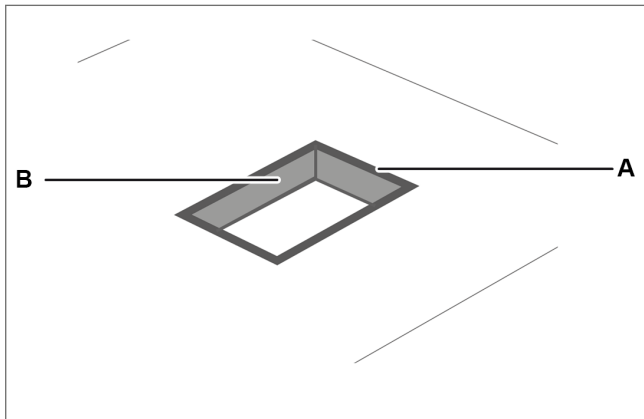

1. On the ceiling of the cold room, drill a hole **[A]** using the air ducting as a template (see Installation Sheet).
2. Adhere the seals **[B]** supplied with the machine to the perimeter of the cut made.

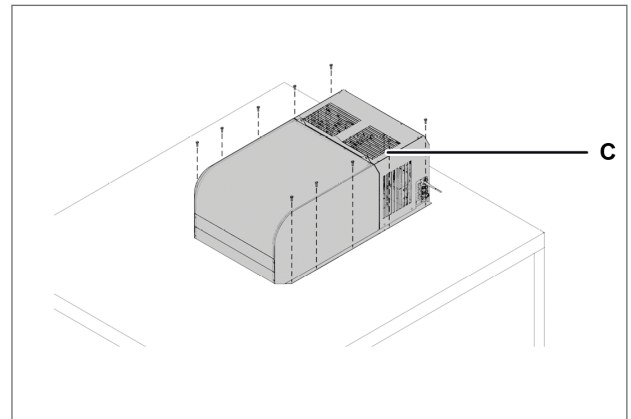

3. Lift the packaged unit using the eyebolts (see "Lifting the packaged unit" on page 10).
4. Place the packaged unit at the hole, with the condensing unit **[C]** facing the nearest wall of the cold room, and secure it with the screws.

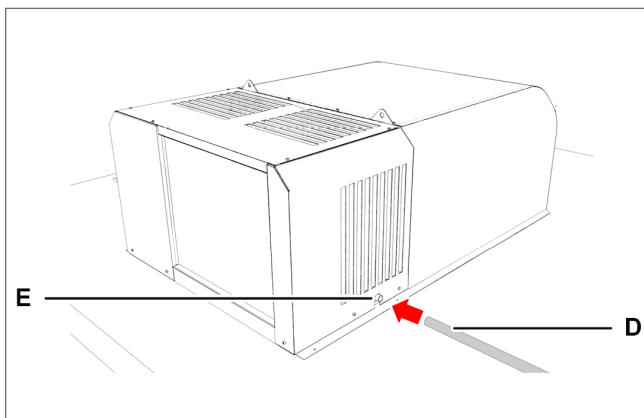

5. Connect the overflow tube **[D]** to the 5/8" (15.9 mm) diameter condensate drain **[E]**.

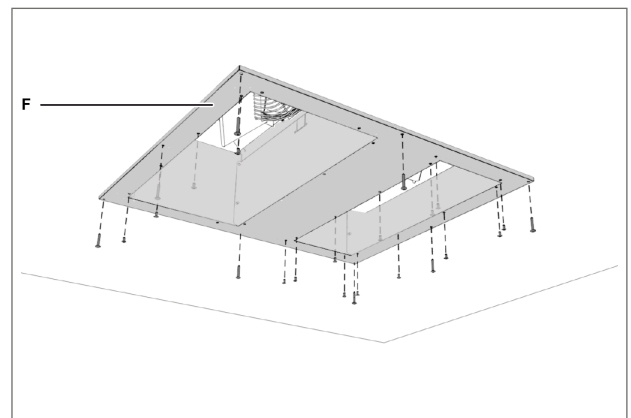

6. On the inside of the ceiling, insert the air duct **[F]** into the hole and fasten it with screws.

NOTICE: avoid tube back-ups which would prevent water from flowing out.

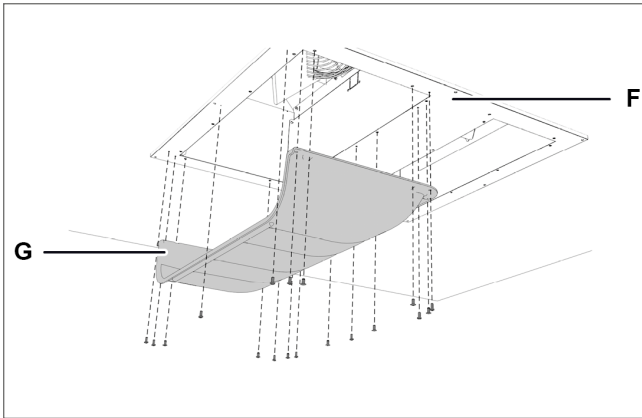

7. Screw the air conveyor [G] to the air ducting [F] with the openings facing the far wall of the cold room.
8. Install the door micro switch (see "Secure the door micro switch" below).
9. Wire the cold room light by connecting it to the packaged unit with the already prepared cable.

5.5 Secure the door micro switch

5.5.1 Safety

⚠ CAUTION

To avoid signal interference, the door micro switch cable must be routed away from power cables.

⚠ CAUTION

The installation of electrical components inside the cold room is the sole responsibility of the end user. Only use suitable materials for the types of risks, in compliance with the laws in force.

5.5.2 Procedure with hinged door

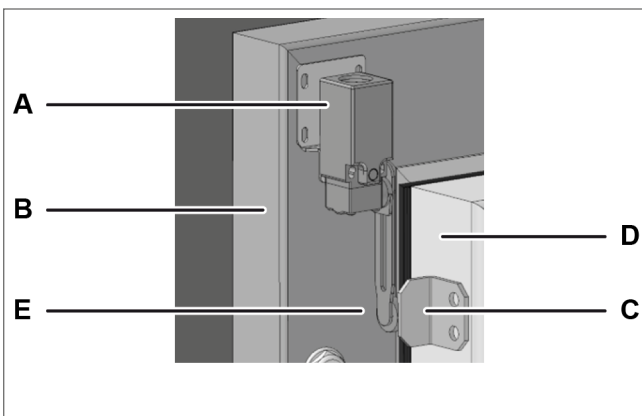

Vertical installation

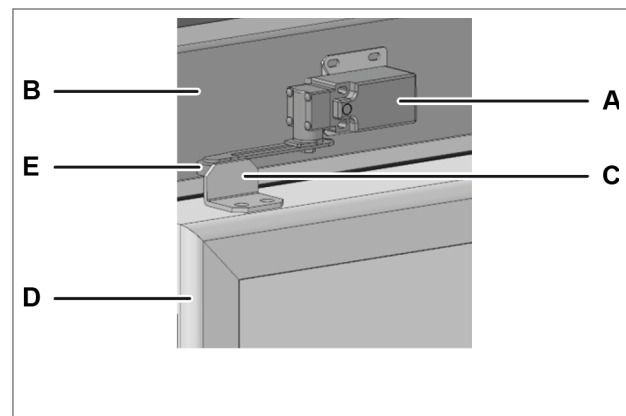

Horizontal installation

1. Fix the door micro switch [A] on the cold room [B] in a horizontal or vertical position, as required.
2. Fasten the latch [C] on the door [D] at the wheel [E].
3. To check that the door micro switch trips, close the cold room door: the door micro switch should trip when the door is fully closed.

5.5.3 Procedure with sliding door

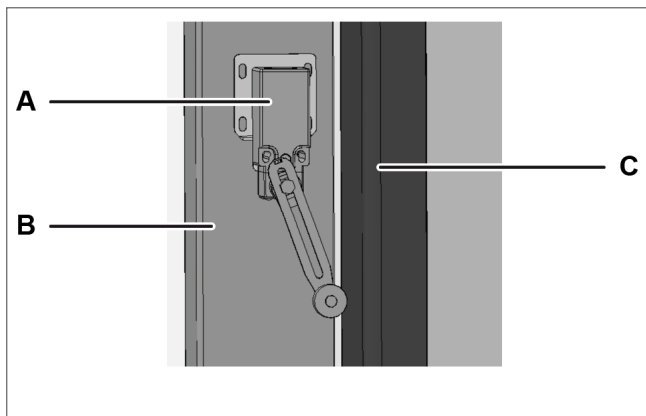

Vertical installation

1. Fasten the door micro switch [A] on the cold room [B].
2. To check that door micro switch trips, close the door [C] of the cold room: the door micro switch should trip when the door is fully closed.

5.6 Connect the packaged unit to the electrical mains

5.6.1 Safety



Electrocution. Always use adequate equipment and accessories and follow the connection warnings given in this instruction manual.

5.6.2 Connect the packaged unit

1. See "Requirements for the connection to the electrical mains" on page 12.
2. Once connected, the display lights up.
3. Switch on the packaged unit (see "Control panel operations" on page 17).

NOTICE : Only start the machine when the ambient temperature is below 32 °C.

5.7 Work area and operational tasks

5.7.1 Required skills



5.7.2 Work area

The work area for the operator is that in front of the control panel.

5.7.3 Operating tasks

The operator sets the packaged unit and checks that it functions correctly.

The operator periodically cleans the packaged unit.

6. Start-up

This section includes the following topics:

6.1 Control panel	16
6.2 Control panel operations	17
6.3 Setting the date and time	18
6.4 Using the MY I.D. App	22
6.5 The passwords	25







6.1 Control panel

6.1.1 Control elements supplied with the packaged unit

It is possible to control the packaged unit via the control panel or via mobile devices connected to the packaged unit via Bluetooth.

6.1.2 Description of the buttons on the control panel



Button	Function	Steady on	Flashing
	Press briefly: returns to the previous menu level. Long press (3 seconds): turns the packaged unit on and off.	Menu navigation in progress.	Switch-on or off in progress
	Press briefly: displays the list of activity alarms. Long press (3 seconds): resets the manually reset alarms.	Alarm cleared and entered in the alarm log.	Packaged unit in alarm state
	Press briefly (3 seconds): turns the light on and off. Long press (6 seconds): manually controls defrost.	-	-
SET	Press briefly: confirms the displayed value. Long press (3 seconds): accesses the setpoint menu. Pressing SET and  simultaneously (3 seconds): accesses the parameters menu.	Setpoint or active parameters menu	-
	Press briefly: scrolls through the menu items or increases the displayed value. Pressing SET and  simultaneously (3 seconds): accesses the parameters menu.	-	Setpoint or active parameters menu
	Press briefly: scrolls through the menu items or decreases the displayed value. Long press (3 seconds): accesses the Quick Menu.	-	Setpoint or active parameters menu

6.1.3 Description of the display





Pilot light	Steady on	Flashing on
	View: <ul style="list-style-type: none"> parameters set values measured values <p>Note: the unit of measurement is not displayed and is factory-set, but can be changed from parameter UM1.</p>	-
	Heating output active	-
	One or more clock functions active: <ul style="list-style-type: none"> Defrost with hourly programming 	-
	Defrosting active	Dripping stage active; defrost request pending
	One or more ECO functions active: <ul style="list-style-type: none"> Smart Defrost active Floating condensation active Energy Saving active 	-
	HACCP alarm triggered: <ul style="list-style-type: none"> High temperature alarm High temperature alarm following blackout Faulty probe alarm 	-
	One or more auxiliary outputs active: <ul style="list-style-type: none"> Discharge heater function active Humidity regulation active General functions active 	-
	Light on	Door closed and delayed light switch-off
	Evaporator-fan active	-
	One or more compressors active	Compressor not enabled at start-up due to: <ul style="list-style-type: none"> Safety device times Open door Start-up delay

6.2 Control panel operations





IMPORTANT: these operations are also possible from the App and do not correspond to the parameters.

6.2.1 Turn the packaged unit on and off



- Turn on: press and hold the  button for 3 seconds. The value of the quantity set in parameter /t1 appears on the display.
- Turn off: and press and hold the  button for 3 seconds. The word **OFF** and the value of the variable set in parameter /t1 alternate on the display.

Note: the ambient temperature must be below 32°C to be able to carry out the first start-up.

6.2.2 Switch the Cold room light on and off

- Switch on: press and hold the  button for 3 seconds and release. The cold room pilot light lights up on the display.
- Switch off: press and hold the  button for 3 seconds and release. The cold room pilot light on the display goes off.

6.2.3 Set the temperature setpoint value





- Press and hold the **SET** button for 3 seconds and release. **SEt** and the temperature setpoint value alternate on the display.
- Briefly press the **SET** button to be able to modify the temperature setpoint value. The display shows the current temperature setpoint value.
- Press the  and  buttons to select the desired temperature setpoint value.
- Briefly press the **SET** button to save the new temperature setpoint value. The value of the quantity set in parameter /t1 appears on the display.

6.2.4 Controlling the manual defrost cycle

- Press and hold the  button for 6 seconds. The defrosting and compressor indicator lights up on the display.

6.2.5 View and reset the active alarms

Flashing text  indicates the presence of triggered alarms.







- Press the  button briefly. The display shows the code of the last triggered alarm.
- Press the  and  buttons to view the codes of the triggered alarms.
- Press and hold the  button for 3 seconds and release to reset the triggered alarms that require a manual reset. **no aLr** appears on the display.

Exiting from a menu

- Briefly press the  button at least once to return to the desired position.

6.3 Setting the date and time

6.3.1 Enter the password

Step	Button	Action	Result
1	SET 	Press and hold simultaneously for 3 seconds and release.	 "PSS" appears on the display.
2	SET	Press briefly.	 "P 0" appears on the display.
3	 	Press briefly to display the relevant number (e.g. select "P 2" to enter number 2). See "The passwords" on page 25.	

Step	Button	Action	Result
4	SET	Press briefly.	 <p>The value is stored. "P 0" appears on the display. Repeat the previous step until the password is entered.</p>
5	SET	Press briefly.	 <p>The first item of the parameters menu appears on the display.</p>

6.3.2 Menu structure with Installer access













1st level		2nd level	
Menu	Description	Menu	Description
CNF	Configuration		
SER	Service	INS	Installer
		CLO	Cloning
I/O	Input/Output	UI	Universal Inputs
		AO	Analogue Outputs
REG	Regulation	CLD	Cooling
		NZ	Neutral Zone
		HUM	Humidity
CMP	Compressor	PRE	Pressure
		TME	Times
		AOM	Compressor analogue output
CND	Condenser	REG	Regulation
		AOC	Condenser analogue output
DEF	Defrost	DFR	Defrost
FAN	Evaporator Fans		
EEV	Electronic Valve	REG	Regulation
		PRO	Protections
DOL	Cold room Door and Light		
ALM	Alarms	IN	Alarms from inputs
		OP	Alarms from operations
		HCP	HACCP Alarms
		ALS	Alarm setting
GEF	General functions	ALF	General alarms
STG	Settings	RTC	Clock
		BMS	Supervision
		NET	Master/Slave
		PWD	Password
		INI	Initialization
		UOM	Unit of measurement
OUT	Logout		

6.3.3 Menu structure with user access

1st level		2nd level	
Menu	Description	Menu	Description
REG	Regulation	CLD	Cooling
		NZ	Neutral Zone
		HUM	Humidity
CND	Condenser	REG	Regulation
ALM	Alarms	HCP	HACCP Alarms
STG	Settings	RTC	Clock
		PWD	Password
		UOM	Unit of measurement
OUT	Logout		

6.3.4 How to modify a parameter

The procedure for changing the cooling differential is shown below as an example.



Step	Button	Action	Result
1	-	Enter the password.	Access enabled.
2	SET	Press and hold simultaneously for 3 seconds and release.	
			"CnF" appears on the display.
3		Press to view the rEG item.	
4	SET	Press briefly.	 "CLD" appears on the display.
5	SET	Press briefly.	 "SEt" appears on the display.
6		Press the arrows to view the parameter.	
7	SET	Press briefly.	 The parameter value appears on the display.
8		Press to set the desired value.	
9	SET	Press briefly.	 The value is stored. The parameter name appears on the display.

6.3.5 Changing the date and time

 StG > rtC

Step	Button	Action	Result
1	SET	From the RTCparameter display, press SET .	
2		TZ appears alternating with a digit indicating the time zone currently set. Press DOWN to skip.	
	SET	Press SET to change the time zone. Note: See "Time zones table" on page 92.	
3		The value of the current time zone set appears fixed. Press UP/DOWN to select the desired value.	
	SET	Press SET to confirm and switch to the next value.	
4		The letter d (day) appears, followed by two digits indicating the number of the day. Press UP/DOWN to set the day.	
	SET	Press SET to confirm and switch to the next value.	
5		The letter m (month) appears, followed by two digits indicating the number of the month. Press UP/DOWN to set the month.	
	SET	Press SET to confirm and switch to the next value.	
6		The letter y (year) appears, followed by two digits indicating the number of the year. Press UP/DOWN to set the year.	
	SET	Press SET to confirm and switch to the next value.	
7		The letter h (hour) appears, followed by two digits indicating the time. Press UP/DOWN to set the time.	
	SET	Press SET to confirm and switch to the next value.	
8		The letter m (minute) appears, followed by two digits indicating the minutes. Press UP/DOWN to set the minutes.	
	SET	Press SET to confirm and conclude the settings.	 "rtC" appears on the display

6.3.6 Exit the menu

Step	Button	Action	Result
1		Press briefly as many times as needed.	 <p>The value of the quantity set in parameter /t1 appears on the display. See configuration parameters.</p>

6.4 Using the MY I.D. App

6.4.1 Using the App for the first time

After switching the packaged unit on, proceed as follows:

1. Download the free MY I.D. App from the Apple App Store or the Google Play Store.
2. Create your Rivacold account.
3. Pair the app to the packaged unit, see "Register the packaged unit using the QR code" on the facing page or "Register the packaged unit using the numeric code" on page 24

6.4.2 Position the QR code

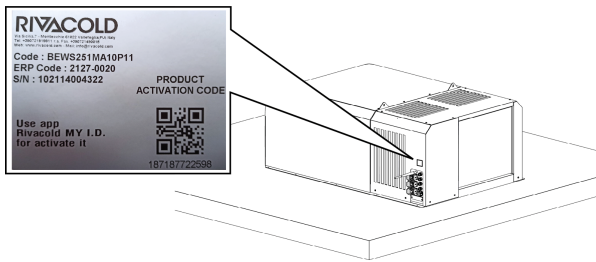

6.4.3 Register the packaged unit using the QR code

1. Select the ☰ menu.

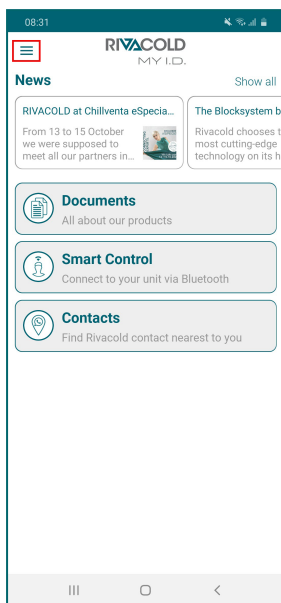

2. Select Unit.

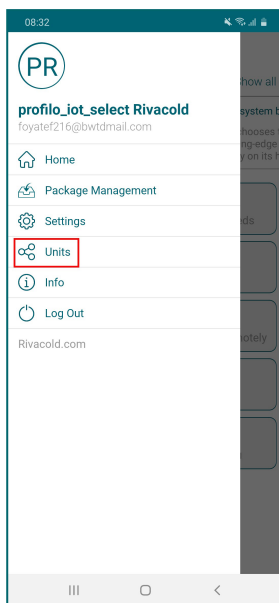

3. Select +.

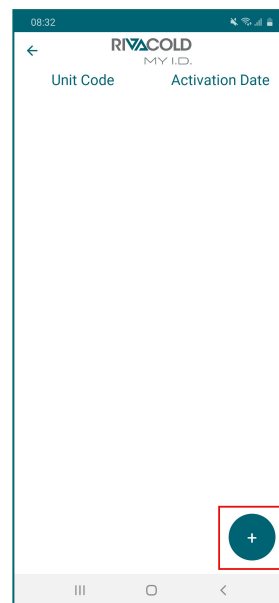

4. Select Scan QR.

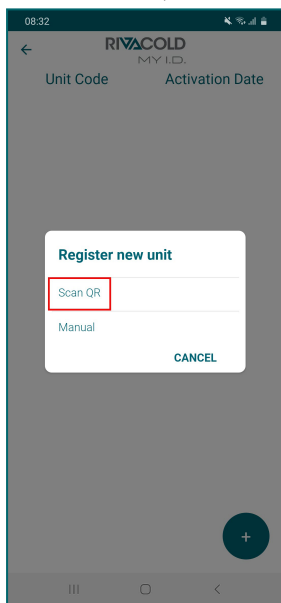

5. Scan the QR code next to the identification plate.



6. Choose the option to share the position. From here on, the packaged unit appears in the list of controlled devices.

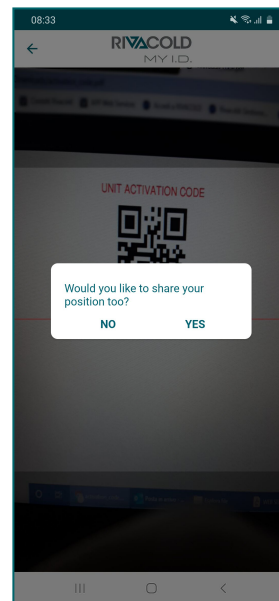

6.4.4 Register the packaged unit using the numeric code

1. Select the menu

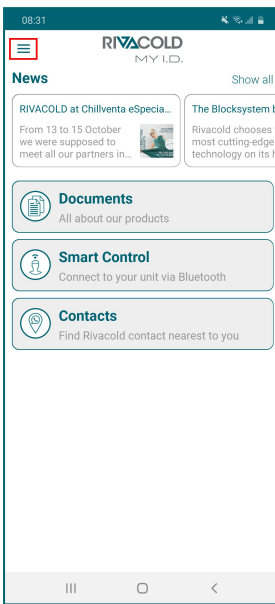

2. Select **Unit**.

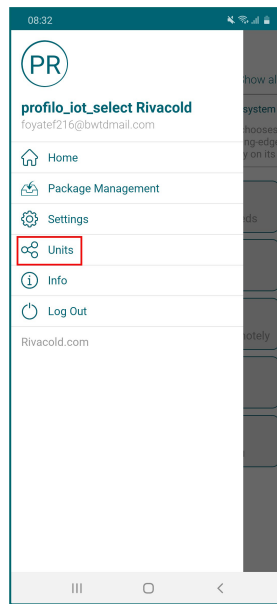

3. Select **+**

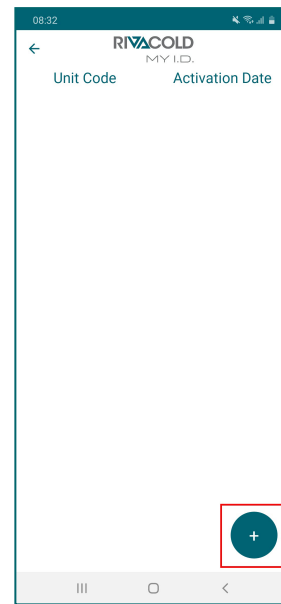

4. Select **Manual**.

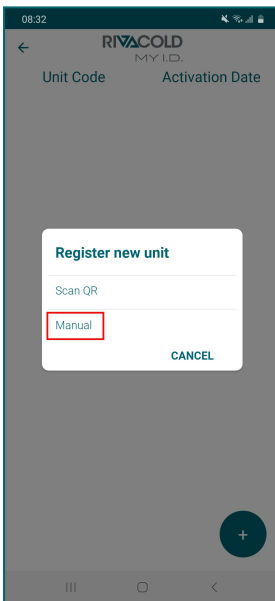

5. Enter the packaged unit code next to the identification plate and select **OK**.

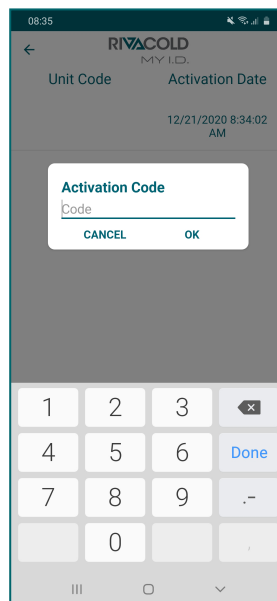

6. Choose the option to share the position. From here on, the packaged unit appears in the list of controlled devices.

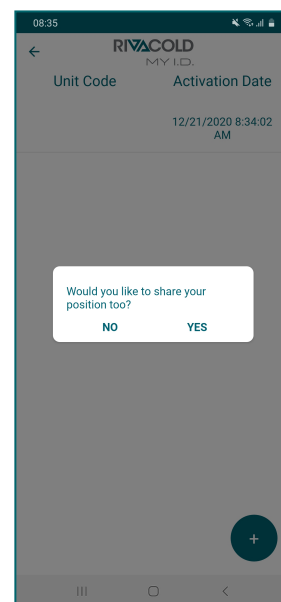

6.4.5 Access the packaged unit via Bluetooth

1. Select **Smart control**.

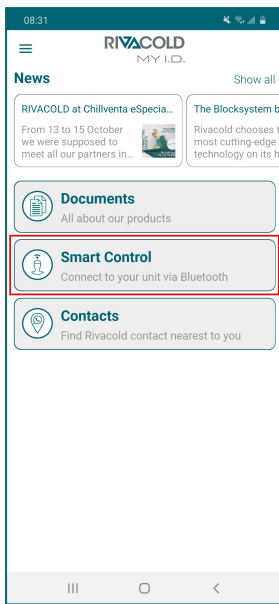

2. Select the packaged unit to be controlled.

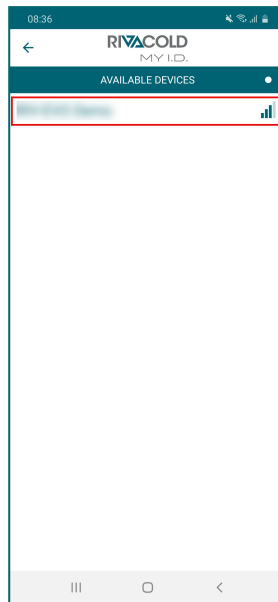

3. Select the profile you want to log in with.

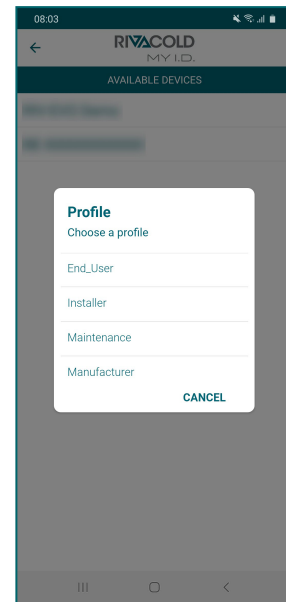

4. Enter the control panel login password, see "The passwords" below.

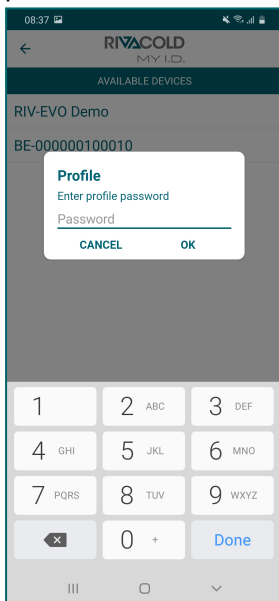

5. Select the desired action.

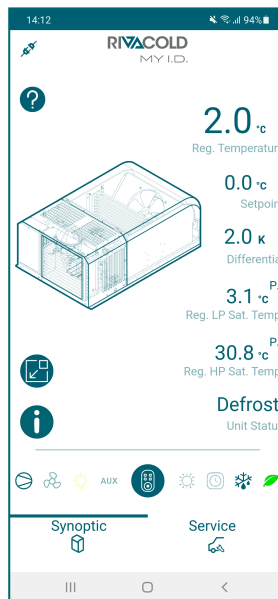

6.5 The passwords

6.5.1 Levels of access to the parameters

Access to the parameters menu and control of the packaged unit from the App are password protected.

There are two levels of access: one for the installer and one for the end user.

After a few minutes of inactivity, the authorisation to modify the parameters expires and the controller returns to the initial screen.

6.5.2 Default password

Below are the preset passwords to access the parameters and the packaged unit via the App. The installer can change both passwords, whereas the end user can only change their own. Refer to the complete manual on the MY I.D. App.

Profile	MY I.D. Profile	Password
End user	End_User	2201
Installer	Installer	2300

7. Quick menu

This section includes the following topics:

7.1 Connecting to the micro USB port	27
7.2 Description of the Quick menu	27
7.3 View the input and output state	28
7.4 Download and upload	31
7.5 Alarm log	32
7.6 HACCP alarm log	32
7.7 System information	34
7.8 Lock and unlock the control panel	35

7.1 Connecting to the micro USB port

7.1.1 When to connect

Perform this procedure when you want to save the configuration of the packaged unit parameters on the external memory.

7.1.2 Procedure

Access the electrical box **[A]** by removing the left side panel **[B]** and the electrical box panel **[C]** (see "Fixed guards" on page 6) and connect to the micro USB port (see "USB port connection" on page 8).

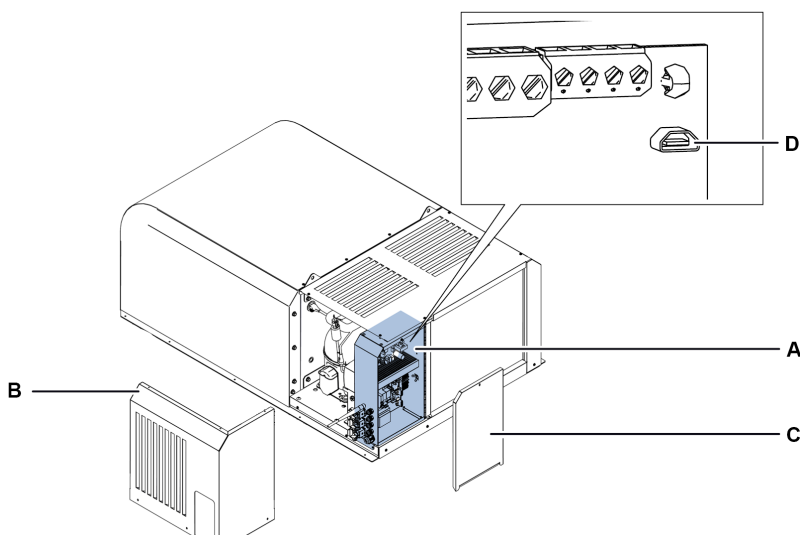





7.2 Description of the Quick menu

7.2.1 Functions

The Quick menu allows direct access to some controller functions:

Function code	Description
IOS	It allows you to view the state of the packaged unit inputs and outputs.
d/U	It allows you to download and upload parameter configurations.
HAL	It allows you to view and save the alarm log.
HCP	It allows you to view and save the HACCP alarm log.
InF	It allows you to view the information about the controller.
LOC	It allows you to lock and unlock the control panel keyboard.

7.2.2 Accessing the quick menu

Step	Button	Action	Result
1		Press and hold for 3 seconds and release.	 The first item of the Quick menu appears on the display.
2		Press briefly to display the desired menu item.	
3	SET	Press briefly.	 The first item of the selected submenu appears on the display.

7.3 View the input and output state

 *Quick menu > IOS*







7.3.1 Available functions

Function code	Description
AI	View the values of the analogue inputs.
di	View the values of the digital inputs.
AO	View the values of the analogue outputs.
dO	View the values of the digital outputs.
EEV	View the values for electronic thermostatic valves.

7.3.2 How to view the status of an input/output

Below is an example of the procedure for viewing the status of input T21 (evaporator temperature probe).

 *IOS > AI*

Step	Button	Action	Result
1		Press and hold for 3 seconds and release.	 The first item of the quick menu appears on the display.
2	SET	Press briefly.	 "AI" appears on the display.
3	SET	Press briefly.	 The first item of the "AI" section appears on the display.
4		Press briefly to view the relevant analogue input.	
5	SET	Press briefly.	 The value detected by the evaporator temperature probe appears on the display.

7.3.3 Input and output table

Unit descriptions	Unit	I/O	I/O Description
Analogue inputs	AI	T11	Cold room temperature probe
		T21	Evaporator temperature probe
		T12	Cold room 2 temperature probe
		T22	Evaporator 2 temperature probe
		LP1	Circuit 1 low pressure probe
		HP1	Circuit 1 high pressure probe
		LP2	Circuit 2 low pressure probe
		HP2	Circuit 2 high pressure probe
		LP3	Circuit 3 low pressure probe
		HP3	Circuit 3 high pressure probe
		STA	Ambient temperature probe
		STL	Suction temperature probe
		STH	Discharge temperature probe
		LIQ	Liquid temperature probe
		STE	Evaporation temperature probe
		BPE	Evaporator pressure probe
		HCP	HACCP temperature probe
		HUM	Humidity probe
		SG1	General probe 1
		SG2	General probe 2
Digital inputs	DI	PSH	High pressure switch
		PSL	Low pressure switch
		PDL	Pump-down pressure switch
		SR1	Door micro switch
		CO1	Compressor 1 alarm
		CO2	Compressor 2 alarm
		CO3	Compressor 3 alarm
		ONF	On/Off from digital input
		EGS	Energy Saving from digital input
		EAL	External serious alarm
		GN1	General input 1
		GN2	General input 2
		Analogue outputs	AO
M1	compressor		
VE1	Evaporator fans		
VE2	Evaporator 2 Fans		
HEA	Heating		
YVW	Water solenoid valve		
GEN	General analogue output		

Unit descriptions	Unit	I/O	I/O Description
Digital outputs	DO	M1	Compressor 1
		M2	Compressor 2
		M3	Compressor 3
		VC	Condenser fans
		DF1	Evaporator defrost
		DF2	Evaporator 2 defrost
		VE1	Evaporator fans
		VE2	Evaporator 2 Fans
		ONF	On/Off from digital output
		ALR	Alarm
		RS1	Evaporator discharge heater
		RS2	Evaporator 2 discharge heater
		YV1	PWM solenoid
		YVL	Liquid solenoid
		YVW	Water solenoid
		HEA	Heating
		HUM	Humidifier
		DEU	Dehumidifier
		VTP	Button thermostatic valve
		HL1	Cold room light
GN1	General output 1		
GN2	General output 2		
Electronic valve	EEV	PC1	Valve opening percentage 1
		ST1	Valve opening step 1
		EP1	Evaporation pressure valve 1
		ET1	Evaporation temperature circuit 1
		SH1	Circuit 1 overheating
		PC2	Valve opening percentage 2
		ST2	Valve opening step 2
		EP2	Evaporation pressure valve 2
		ET2	Evaporation temperature circuit 2
		SH2	Circuit 2 overheating
		PC3	Valve opening percentage 3
		ST3	Valve opening step 3
		EP3	Evaporation pressure valve 3
		ET3	Evaporation temperature circuit 3
		SH3	Circuit 3 overheating

7.4 Download and upload

7.4.1 Available functions

Note: the packaged unit must be in **OFF**.

 Quick menu > d/L

Function code	Description
dnL	Download the parameter configuration currently in use
UPL	Upload a configuration
dLL	Download the logs generated during operation
SOF	Update the controller software











7.4.2 How to download

Below is an example of the procedure for downloading the parameters in use.

Note: you must be logged in as an installer to start downloading the parameter configuration, see Passwords.

Note: The following procedure also applies for UPL, dLL and SOF functions.

 d/L > dnL

Step	Button	Action	Result
1		Press and hold for 3 seconds and release.	 The first item of the Quick menu appears on the display.
2		Press briefly to display the desired menu item.	
3	SET	Press briefly.	
4	SET	Press briefly.	 "no" appears on the display.
5		Press briefly.	
6	SET	Press briefly.	 If the save function has been completed correctly, "dOn" will appear on the display.  If the save function was not successful, "Err" will appear on the display. Repeat the operation.

Note (*): The parameter configuration is saved in a file in txt format whose name is Export_1

7.5 Alarm log









7.5.1 Available functions

 *Quick menu > HAL*

Function code	Description
ALL	View the alarm log
dLA	Download the alarm log

7.5.2 How to view the alarm log

 *HAL > ALL*

Step	Button	Action	Result
1		Press and hold for 3 seconds and release.	 The first item of the Quick menu appears on the display.
2		Press briefly to display the desired menu item.	
3	SET	Press briefly.	 "ALL" appears on the display.
4	SET	Press briefly.	 The display shows the code of the last logged alarm.
5		Press briefly to view the alarm codes in the log.	

7.6 HACCP alarm log

 *Quick menu > HCP*









7.6.1 Available functions

Function code	Description
HC1	View the HACCP high temperature alarm log.
HC2	View the HACCP faulty probe alarm log.
HC3	View the HACCP blackout alarm log.
DLH	Download the HACCP alarm log.

7.6.2 How to view HACCP alarm log











Below is an example of the procedure for displaying the HACCP alarm log for high temperature.



 *Quick menu > HCP > HC1*

Step	Button	Action	Result
1		Press and hold for 3 seconds and release.	 The first item of the Quick menu appears on the display.
2		Press briefly to display the desired menu item.	
3	SET	Press briefly.	 "HC1" appears on the display.
4	SET	Press briefly.	 The temperature logged in the last HACCP alarm appears on the display.
5		Press briefly to view the temperatures logged in the HACCP alarm log.	

7.6.3 Download the HACCP alarm log

 *Quick menu > HCP > DLH*

Step	Button	Action	Result
1		Press and hold for 3 seconds and release.	 The first item of the Quick menu appears on the display.
2		Press briefly to display the desired menu item.	
3	SET	Press briefly.	 "HC1" appears on the display.
4		Press briefly to display the desired menu item.	
5	SET	Press briefly.	 "no" appears on the display.
6		Press briefly.	

Step	Button	Action	Result
7	SET	Press briefly.	 <p>If the save function has been completed correctly, "dOn" will appear on the display.</p>  <p>If the save function was not successful, "Err" will appear on the display. Repeat the operation.</p>

7.7 System information







 *Quick menu > InF*

7.7.1 Available functions

Function code	Description
VEr	View the version of the software installed on the controller.
OS	View the version of the operating system installed on the controller.
BOt	View the start-up version.
RTC	About Clock and Timezone

7.7.2 View the version of the installed software









 *InF > VEr*

Step	Button	Action	Result
1		Press and hold for 3 seconds and release.	 <p>The first item of the Quick menu appears on the display.</p>
2		Press briefly to display the desired menu item.	
3	SET	Press briefly.	 <p>"VEr" appears on the display.</p>
4	SET	Press briefly.	 <p>The version of the software installed on the controller appears on the display.</p>





7.8 Lock and unlock the control panel

7.8.1 Lock the control panel

 Quick menu > LOC

Step	Button	Action	Result
1		Press and hold for 3 seconds and release.	 The first item of the Quick menu appears on the display.
2		Press briefly to display the desired menu item.	
3	SET	Press briefly.	 "YES" appears on the display. 
4	SET	Press briefly.	  "LOC" appears on the display for a few seconds.

7.8.2 Unlock the control panel

Step	Button	Action	Result
1	 	Press simultaneously for 3 seconds.	  "unL" and the value of the variable set in parameter /t1 appear on the display for a few seconds, see "Configuration parameters" on page 37.

8. Parameters

This section includes the following topics:

8.1 Structure of the parameters menu	36
8.2 Configuration parameters	37
8.3 Restore default parameters	39
8.4 Service parameters	40
8.5 Input/Output Parameters	40
8.6 Regulation parameters	41
8.7 Compressor parameters	42
8.8 Condenser parameters	43
8.9 Defrost parameters	44
8.10 Evaporator fan parameters	46
8.11 Electronic valve parameters	47
8.12 Electronic valve protections	49
8.13 Cold room light and door micro switch parameters	51
8.14 Parameters of the alarms	51
8.15 General function parameters	56
8.16 General setting parameters	58

8.1 Structure of the parameters menu

8.1.1 Menu structure with Installer access

1st level		2nd level	
Menu	Description	Menu	Description
CNF	Configuration		
SER	Service	INS	Installer
		CLO	Cloning
I/O	Inputs/Outputs	UI	Universal Inputs
		AO	Analogue Outputs
REG	Regulation	CLD	Cooling
		NZ	Neutral Zone
		HUM	Humidity
CMP	Compressor	PRE	Pressure
		TME	Times
		AOM	Compressor analogue output
CND	Condenser	REG	Regulation
		AOC	Condenser analogue output
DEF	Defrost	DFR	Defrost
FAN	Evaporator Fans		
EEV	Electronic Valve	REG	Regulation
		PRO	Protections
DOL	Cold room Door and Light		
ALM	Alarms	IN	Alarms from inputs
		OP	Alarms from operations
		HCP	HACCP Alarms
		ALS	Alarm setting
GEF	General functions	ALF	General alarms

1st level		2nd level	
Menu	Description	Menu	Description
STG	Settings	RTC	Clock
		BMS	Supervision
		NET	Master/Slave
		PWD	Password
		INI	Initialization
		UOM	Unit of measurement
OUT	Logout		

8.1.2 Menu structure with user access

1st level		2nd level	
Menu	Description	Menu	Description
REG	Regulation	CLD	Cooling
		NZ	Neutral Zone
		HUM	Humidity
CND	Condenser	REG	Regulation
ALM	Alarms	HCP	HACCP Alarms
STG	Settings	RTC	Clock
		PWD	Password
		UOM	Unit of measurement
OUT	Logout		

8.2 Configuration parameters

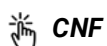

8.2.1 List of parameters

Parameter	Description	Options	Unit of measurement	Range	Default (*)
Unit	Selecting the pre-configuration to be applied to the unit	1 – BEST WT Medium Temperature with 1 Compressor	-	1...99	0
		2 – BEST WT Low Temperature with 1 Compressor			
		3 – BEST WT Medium Temperature with 2 Compressors			
		4 – BEST WT Low Temperature with 2 Compressors			
UnG	Selecting the Refrigerant Gas	Gas code (**)	-	1...40	7
Con	Condensing Management	1 – AIR – Parallel with Compressor	-	1...5	Air: 1 Water: 4
		2 – AIR – On/Off			
		3 – AIR – Variable Speed			
		4 – WATER – On/Off			
		5 – WATER – Flow Rate Control			

Parameter	Description	Options	Unit of measurement	Range	Default (*)
P U t	Selecting the Electronic Valve	0 – None	-	0...2	0
		1 – Button Electronic Valve			
		2 – Stepper Electronic Valve			
P U n	Selecting the Stepper Valve model	0 - Defined by the User	-	0...9	1
		1 - Carel E2Vu			
		2 - Danfoss/Saginomya KV			
		3 - Sporlan ESX			
		4 - Alco EXM/EXL			
		5 - Sanhua L Series			
		6 - Hualu DPF 12V			
		7 - Hualu SPF 12V			
		8 - Hualu EPF-VPF 12V			
9 - Sanhua LPF					
r t i	Selecting the display view	1 - Cold room temperature probe	-	1...9	9
		2 - Evaporator 1 temperature probe			
		3 - Cold room 2 temperature probe			
		4 - Evaporator 2 temperature probe			
		5 - Humidity probe			
		6 - Generic probe 1			
		7 - Generic probe 2			
		8 - Cooling setpoint			
		9 - Cooling regulation temperature probe			

Note (*): LV and TN parameters the same except where indicated.

Note ()**: gas code

1 - R22	6 - R507A	11 - R744	16 - R413A	21 - R245FA	26 - R23	31 - R442A	36 - R452A
2 - R134a	7 - R290	12 - R728	17 - R422A	22 - R407F	27 - HFO1234yf	32 - R447A	37 - R508B
3 - R404A	8 - R600	13 - R1270	18 - R423A	23 - R32	28 - HFO1234ze	33 - R448A	38 - R452B
4 - R407C	9 - R600a	14 - R417A	19 - R407A	24 - HTR01	29 - R455A	34 - R449A	39 - R513A
5 - R410A	10 - R717	15 - R422D	20 - R427A	25 - HTR02	30 - R170	35 - R450A	40 - R454B

8.2.2 Parameter CoM

Air condensing

- **CoM** = 1: parallel with the compressor. The fans start up simultaneously with the activation of at least one of the compressors. The fans are off if defrosting with hot gas.
- **CoM** = 2: ON/OFF. The fans start-up is controlled by the value of the condensing pressure:
 - with the regulation condensing pressure higher than **SCO**, the fans are active.
 - with the regulation condensing pressure less than **SCO - dCO**, the fans stop.
- **CoM** = 3: variable speed. The fans start-up is controlled by the value of the condensing pressure and their rotation speed varies according to the condensing regulation:
 - with the regulation condensing pressure higher than **(SCO - dCO) + AOF**, the fans run at controlled speed.
 - with the regulation condensing pressure the same as **SCO + dCO**, the fans run at maximum speed.
 - with the regulation condensing pressure less than **SCO - dCO**, the fans stop.

Note: for the description of parameters **SCO**, **dCO** and **AOF** see "Condenser parameters" on page 43.





Water-cooled condenser

- **CoM = 4:** ON/OFF. The water solenoid is always active when the packaged unit is on. The water solenoid is only deactivated during defrost.
- **CoM = 5:** flow rate control. The water solenoid is regulated according to the regulation condensing pressure value to keep it at the setpoint value. The water solenoid is only deactivated during defrost.

8.3 Restore default parameters

8.3.1 Procedure

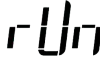
How to reset all parameters to the default value according to the machine configuration (perform the procedure with the machine in OFF state).

Step	Button	Action	Result
1	-	Enter the password. See "Enter the password" on page 18.	Access enabled
2	SET ▲	Press and hold simultaneously for 3 seconds and release.	 "CnF" appears on the display.
3	SET	Press briefly.	 "Unt" appears on the display.
4	SET	Press briefly.	 "n 1" appears on the display.
5	▲ ▼	Use the arrows to select the desired configuration from those available: 1. BEST WT NT 1 compressor 2. BEST WT LT 1 compressor 3. BEST WT NT 2 compressors 4. BEST WT LT 2 compressors	
6	SET	Press briefly.	 "rUn" appears on the display.  At the end of the process, the display shows "dOn"
7		When finished, press briefly 4 times to return to the main screen.	

8.4 Service parameters

8.4.1 List of installer parameters

 *SEr > InS*

Parameter	Description	Options	Unit of measurement	Range	Default (*)
Chd	Selects the type of Terminal	0 - pLed 1 - pGD	-	0...1	0

Note ()*: LV and TN parameters the same except where indicated.

8.5 Input/Output Parameters

8.5.1 Universal Inputs

 *I/O > UI*

Parameter	Description	Options	Unit of measurement	Range	Default (*)
U17	Offset value for UI1 (Cold room temperature probe)	-	°C/°F	99.9...+99.9	0
U27	Offset value for UI2 (evaporator temperature probe)	-	°C/°F	99.9...+99.9	0
U37	Offset value for UI3 (relative to input B3 of the board)	-	Bar/PSI - °C/°F	99.9...+99.9	0
U47	Offset value for UI4 (relative to input B4 of the board)	-	Bar/PSI - °C/°F	99.9...+99.9	0
U57	Offset value for UI5 (relative to input B5 of the board)	-	Bar/PSI - °C/°F	99.9...+99.9	0
U67	Offset value for UI6 (relative to board input B6)	-	Bar/PSI - °C/°F	99.9...+99.9	0
U77	Offset value for UI7 (relative to input B7 of the board)	-	Bar/PSI - °C/°F	99.9...+99.9	0
U87	Offset value for UI8 (relative to input B8 of the board)	-	Bar/PSI - °C/°F	99.9...+99.9	0

Note ()*: LV and TN parameters the same except where indicated.

8.5.2 Analogue Outputs

 *I/O > AO*

Parameter	Description	Options	Unit of measurement	Range	Default (*)
P13	Selecting the minimum value of analogue output AO1 (Relative to output Y1 of the board)	-	%	0.0...Y14	0
P14	Selecting the maximum value of analogue output AO1 (Relative to output Y1 of the board)	-	%	Y13...100.0	100

Parameter	Description	Options	Unit of measurement	Range	Default (*)
Y23	Selection of minimum value of analogue output AO2 (Relative to output Y2 of the board)	-	%	0.0...Y24	0
Y24	Selecting the maximum value of analogue output AO2 (Relative to output Y2 of the board)	-	%	Y23...100.0	100

Note (*): LV and TN parameters the same except where indicated.

8.6 Regulation parameters

8.6.1 List of cooling parameters

 *rEG > CLd*

Parameter	Description	Options	Unit of measurement	Range	Default (*)
Set	Cooling Setpoint	-	°C/°F	LSE...HSE	NT: 0 LT: -20
dIF	Cooling Differential	-	K/°F	0...99.9	2
OSP	Energy Saving Offset for Cooling Setpoint	-	K/°F	-20.0...20.0	5
brM	Enables emergency operation when the regulation probe is faulty	0 - No	-	0...1	1
		1 - Yes			
brC	Cycle time for emergency operation if the regulation probe is faulty	-	min	0...99	30

Note (*): LV and TN parameters the same except where indicated.

8.6.2 OSP parameter

The **OSP** parameter is an offset that can be applied to the setpoint **Set** when the Energy Saving function is enabled from **DI** or **BMS**.

8.6.3 Parameters brM and brC

Parameter **brM** activates the emergency operation if the regulation probe breaks. Operation involves the cyclical switch-on and off of the unit for the time defined by **brC**.

Note: the emergency operation cannot be set as a standard setting or for long times.

8.6.4 List of neutral zone parameters

 *rEG > NZ*

Parameter	Description	Options	Unit of measurement	Range	Default (*)
dnZ	Neutral Zone Differential	-	K/°F	0...99.9	2
dHE	Heating Differential	-	K/°F	0...99.9	2

Note (*): LV and TN parameters the same except where indicated.

8.6.5 Parameter dnZ

It defines the interval around the **Set** temperature, within which the cooling demand and the heating demand are reset.

8.6.6 List of humidification/dehumidification parameters

 *rEG > HUM*

Parameter	Description	Options	Unit of measurement	Range	Default (*)
S h U	Humidification Setpoint	-	%	LHU...HHU	80
d h U	Humidification Differential	-	%	0...99.9	10
S d E	Dehumidification Setpoint	-	%	LDE...HDE	30
d d E	Dehumidification Differential	-	%	0...99.9	10

Note ()*: LV and TN parameters the same except where indicated.

8.7 Compressor parameters

8.7.1 List of pressure parameters

 *CMP > PrE*

Parameter	Description	Options	Unit of measurement	Range	Default (*)
S P r	Pressure Setpoint for Variable Compressor Capacity regulation	-	bar/psi	LPR...HPR	0.8
d P r	Pressure Differential for Variable Compressor Capacity regulation	-	bar/psi	0...99.9	0.4
i P r	Integral Time for Compressor PID Regulation	-	s	0...999	100
t P d	Pump-Down stop threshold from regulation suction pressure	-	bar/psi	A65...99.9	1.4
d P d	Pump-Down stop differential from regulation suction pressure	-	bar/psi	0...99.9	0.3
t o P	Maximum time for Pump-Down stop	-	min	0...999	5

Note ()*: LV and TN parameters the same except where indicated.

8.7.2 List of timing parameters

 **CMP > tME**

Parameter	Description	Options	Unit of measurement	Range	Default (*)
0 d 0	Unit start delay upon start-up or after a Blackout	-	s	0...999	60

Note (*): LV and TN parameters the same except where indicated.

8.7.3 List of cooling parameters

 **CMP > CLd**

Parameter	Description	Options	Unit of measurement	Range	Default (*)
R 0 C	Minimum value for Compressor Analogue Output	-	%	0...100	0

Note (*): LV and TN parameters the same except where indicated.

8.8 Condenser parameters

8.8.1 List of regulation parameters

 **Cnd > rEG**

Parameter	Description	Options	Unit of measurement	Range	Default (*)
S C 0	Condensing regulation Pressure Setpoint	-	bar/psi	LCO...HCO	12
d C 0	Condensing regulation Pressure Differential	-	bar/psi	0...99.9	2
, C 0	Integral Time for Condensing PID Regulation	-	s	0...999	100
E F C	Enable Floating Condensing operation	0 - Disable 1 - Enable	-	0...1	0
d F C	Constant value for Floating Condensation	-	K/°F	-99.9...99.9	2

Note (*): LV and TN parameters the same except where indicated.

8.8.2 Parameter EFC

Floating condensation

In floating condensation, condensation regulation is not linked to the value of parameter **SCO**, but the threshold value changes according to the ambient temperature.

Note: the floating condensation is only used with air condensation and requires an ambient temperature probe to be installed.

8.8.3 List of analogue output parameters

 Cnd > AOM

Parameter	Description	Options	Unit of measurement	Range	Default (*)
A O F	Minimum value for Compressor Analogue Output	-	%	0...100	30
S u t	Speed Up Time	-	s	0...999	0

Note (*): LV and TN parameters the same except where indicated.

8.8.4 Parameter Sut

Useful in the case of traditional fans which need more electric current at start-up. The value of the analogue output of the condenser fans is forced to the maximum for the set time, at the end of which, the value of the analogue output returns to the regulation value.

8.9 Defrost parameters

8.9.1 List of parameters

 dEF > dFr

Parameter	Description	Options	Unit of measurement	Range	Default (*)
d t P	Selecting the type of defrost	0 - None	-	0...3	3
		1 - Clock			
		2 - Intervals			
		3 - Smart Defrost			
d S n	Selecting the defrost mode	1 - Hot Gas	-	0...3	1
		2 - Heater			
		3 - Static			
d E n	Selecting the defrost End mode	1 - Maximum Time	-	0...2	2
		2 - Maximum Temperature or Time			
d 2 E	Selecting the defrost mode with 2 Evaporators	1 - Simultaneous	-	1...2	1
		2 - Sequential			
d i t	Interval between 2 Defrost cycles	-	h/min	0...999	6
d 1	Enables and sets time for Defrost 1	-	-	-	0
d 2	Enables and sets time for Defrost 2	-	-	-	0
d 3	Enables and sets time for Defrost 3	-	-	-	0
d 4	Enables and sets time for Defrost 4	-	-	-	0
d 5	Enables and sets time for Defrost 5	-	-	-	0

Parameter	Description	Options	Unit of measurement	Range	Default (*)
d 6	Enables and sets time for Defrost 6	-	-	-	0
d 7	Enables and sets time for Defrost 7	-	-	-	0
d 8	Enables and sets time for Defrost 8	-	-	-	0
d 9	Enables and sets time for Defrost 9	-	-	-	0
d 10	Enables and sets time for Defrost 10	-	-	-	0
d t 1	Defrost end temperature for Evaporator	-	°C/°F	-99.9...99.9	5
d S 1	Defrost maximum time for Evaporator (**)	-	min/s	0...999	15
d t 2	Defrost end temperature for Evaporator 2	-	°C/°F	-99.9...99.9	10
d S 2	Defrost maximum time for Evaporator 2 (**)	-	min/s	0...999	15
d b 0	Enables Defrost after Blackout	0 - No	-	0...999	0
		1 - Yes			
t b 0	Minimum Blackout time to start defrost	-	min	0...999	60
d 0 H	Defrost delay at start-up	-	min	0...999	0
d d L	Selecting the Display view during Defrost	1 - Fixed 'DFR' symbol on display during defrosting	-	1...4	1
		2 - Cold room regulation temperature			
		3 - Cold room regulation temperature value when defrost begins			
		4 - Fixed 'DFR' symbol on display with delayed disappearance after defrosting			
t b 1	Selects a unit of measurement for interval times and maximum defrost time	0 - Interval in hours / Maximum time in minutes	-	0...1	0
		1 - Interval in minutes / Maximum time in seconds			
t d c	Stand-by time before skipping defrost due to interval	-	min	0...999	15
d t	Dripping time	-	min	0...999	3
d r H	Discharge heater activation times	-	min	0...999	5

Note (*): LV and TN parameters the same except where indicated.

8.9.2 Parameters d1 ... d10

Parameters **d1** to **d10** allow you to set up to 10 different times to activate defrost. Activate the timed defrost by setting parameter **dtY** = 1.

8.9.3 Parameter dOH

When the packaged unit starts, the controller cancels a defrost cycle if it is set to start in a shorter time than that set by parameter **dOH**.

8.9.4 Parameter tdc

Defrosting is subject to conditions which prevent it from starting if not fully met. If the defrost is not started, the controller waits for the operation to start within a time defined by parameter **tdc**. If after this time defrosting has not started, the controller cancels the operation and displays an alarm for 5 seconds.

8.9.5 Parameter drH

For all types of defrost. Sets the advance time in which the drain heaters, if configured, are activated with respect to the start-up of defrost. The same time interval is used to command the switch-off of the drain heaters after the end of defrosting.

In case of manual defrost, the drain heaters are activated the same time as defrost and deactivated after the **drh** time, when defrosting is completed.

8.10 Evaporator fan parameters



FAn

8.10.1 List of parameters

Parameter	Description	Options	Unit of measurement	Range	Default (*)
F P n	Selects the regulation mode for the Evaporator Fans	1 – Always On 2 – On during Cooling regulation 3 – On during the cooling, heating, humidification and dehumidification regulations.	-	1...3	2
F P b	Selects the regulation probe of the Evaporator Fans	1 – Evaporator temperature probe 2 – Saturated Temperature from low pressure probe	-	1...2	2
F S 1	Temperature threshold for Evaporator Fan stop	-	°C/°F	-99.9...99.9	NT: 10 LT: -10
d F 1	Differential for Evaporator Fan activation	-	K/°F	0...99.9	5
F S 2	Temperature threshold for Evaporator 2 Fan stop	-	°C/°F	-99.9...99.9	NT: 10 LT: -10
d F 2	Differential for Evaporator 2 Fan activation	-	K/°F	0...99.9	5
F d t	Post-dripping time	-	min	0...999	NT: 1 LT: 3

Parameter	Description	Options	Unit of measurement	Range	Default (*)
d F d	Enables Evaporator Fan operation during the Defrost stage	0 - No 1 - Yes	-	0...1	0
E F S	Enables Evaporator Fan operation during stand-by	0 - No 1 - Yes	-	0...1	0
d F S	Anti-stratification cycle start delay during unit Stand-By	-	Min	0...999	15
C F C	Anti-stratification cycle time during unit Stand-By	-	Min	0...999	5

Note (*): LV and TN parameters the same except where indicated.

8.10.2 Parameter Fdt

After the dripping stage, the fans remain deactivated, even in the presence of activation commands, for the time set in parameter **Fdt**.

8.10.3 Anti-stratification - EFS, dFS and CFC parameters

This function can be activated via the EFS parameter and allows you to activate, after the time set via the dFS parameter, an ON/OFF cycle of the evaporator fans, to avoid stratification of the air inside the cold room, since, when the fans are stopped, the cooler air will tend to accumulate towards the lower part of the cold room, while the warmer air will tend to accumulate towards the top, thus distorting the reading of the actual temperature in the cold room.

This function will activate the fans and thus mix the air inside the cold room, equalising the temperature.

The cycle time is unique for both ON and OFF and can be set via the CFC parameter.

Below is a representation of the behaviour of the anti-stratification function:

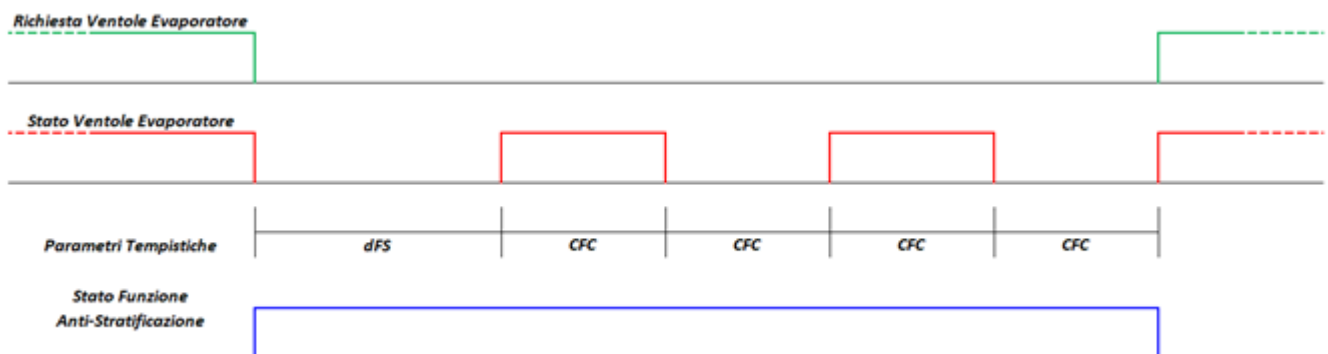

8.11 Electronic valve parameters

8.11.1 List of regulation parameters

 EEV > REG

Parameter	Description	Options	Unit of measurement	Range	Default (*)
S S H	Overheating Setpoint	-	K/°F	P7...99.9	6
G S H	PID: Proportional Gain	-	-	0.0...800.0	15

Parameter	Description	Options	Unit of measurement	Range	Default (*)
i S H	PID: Integral Time	-	s	0.0...999.0	100
d S H	PID: Derivative Time	-	s	0.0...999.0	2
P d d	Regulation delay time after Defrost	-	min	0...999	0
[P 1	Valve opening upon start	-	%	0...100	50
[P 2	Pre-positioning time	-	s	0...999	6
P S b	Valve position in stand-by	-	%	0...100	0
E n S	Enable smooth-line function	0 - No	-	0...1	0
		1 - Yes			

Note (*): LV and TN parameters the same except where indicated.

8.11.2 Adjusting the delay after defrost (Pdd)

Following a defrost cycle, the reading of the overheating value can be distorted by the temperature reached by the parts of the packaged unit during the process.

The **Pdd** parameter sets a time interval at the end of the defrost cycle, during which the electronic valve is blocked with the opening set by the **CP1** parameter, to avoid unwanted tripping of the protections. Once this time interval elapses, the electronic valve function is restored.

8.11.3 List of parameters for the protections

 **EEV > PrO**

Parameter	Description	Options	Unit of measurement	Range	Default (*)
P 7	Low Overheating Protection: Threshold	-	K/°F	5.0...SSH9-	2
P 8	Low Overheating Protection: Integral Time	-	s	0.0...800.0	10
P 9	Low Overheating Protection: Alarm Delay	-	s	1...999	120
P L 1	Low Evaporation Pressure Protection: Threshold	-	°C/°F	-85.0...PM1-	NT: -20 LT: -35
P L 2	Low Evaporation Pressure Protection: Integral Time	-	s	0.0...800.0	10
P L 3	Low Evaporation Pressure Protection: Alarm Delay	-	s	1...999	120
P n 1	High Evaporation Pressure Protection: Threshold	-	°C/°F	PL1...99.9	7
P n 2	High Evaporation Pressure Protection: Integral Time	-	s	0.0...800.0	20

Parameter	Description	Options	Unit of measurement	Range	Default (*)
P7	High Evaporation Pressure Protection: Alarm Delay	-	s	1...999	120

Note (*): LV and TN parameters the same except where indicated.

8.12 Electronic valve protections

Protection	Description of the protection	Task	Reset
LOW_SH	Low overheating	Valve closure	Immediate
LOP	Low evaporation pressure	Valve opening	Immediate
MOP	High evaporation pressure	Valve closure	Controlled

8.12.1 Low overheating protection

The low overheating protection trips when the overheating value is too low and there is a risk of liquid returning to the compressor.

The protection actuates the electronic valve and commands its partial closure. The degree of closure of the valve and the tripping time are controlled by the difference between the detected overheating temperature value (SH) and the low heating protection threshold (LOW_SH_TH).

The low heating protection threshold value must be less than or equal to the overheating setpoint **SSH** to prevent the low heating protection from tripping during correct operation.

The following graph shows the tripped low heating protection:

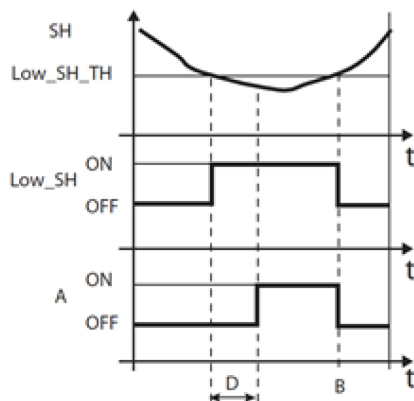

Quantity	Description
SH	Overheating
LOW_SH_TH	Low overheating protection threshold. Parameter: P7
LOW_SH	Low heating protection
B	Automatic alarm reset
A	Alarm
D	Alarm delay. Parameter: P9
t	Time

8.12.2 Low evaporation pressure protection

The low evaporation pressure protection (LOP) trips when the evaporation temperature is too low, to prevent the compressor from stopping due to the tripped low pressure switch.

This protection is particularly useful in multistage systems during the starting stage or if there is an increase in the cooling demand, where the evaporation temperature tends to drop quickly.

The value to be entered as parameter **PL1**, low evaporation pressure protection threshold, is the saturated evaporation temperature, which the controller uses to trace the pressure value.

The value of **PL1** must be lower than the nominal evaporation temperature of the machine and higher than the calibration value of the low pressure switch.

The protection actuates the electronic valve, commanding the opening action and increasing the pressure to prevent the low pressure switch from tripping. The opening degree of the valve and the tripping time are controlled by the difference between the detected evaporation temperature value (T_EVAP) and the low evaporation pressure protection threshold (LOP_TH).

The alarm triggered by the low evaporation pressure protection (id = 37) can also indicate a refrigerant leak from the circuit and the consequent drop in the evaporation temperature.

The following chart shows the tripped low evaporation pressure protection:

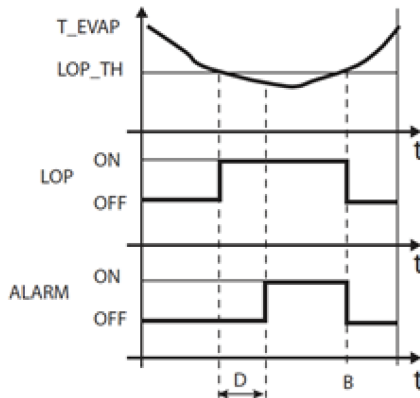

Quantity	Description
T_EVAP	Evaporation temperature
LOP_TH	Low evaporation pressure protection threshold. Parameter: PL1
LOP	Low evaporation pressure protection
B	Automatic alarm reset
ALARM	Alarm
D	Alarm delay. Parameter: PL3
t	Time

8.12.3 High evaporation pressure protection

The high evaporation pressure protection trips when the evaporation temperature is too high. An excessive evaporation temperature can lead to an overload in the compressor and the possible tripping of the thermal protections.

The high evaporation pressure protection threshold **PM1** is the saturated evaporation temperature, which the controller uses to trace the pressure value.

The protection actuates the electronic valve and commands its partial closure.

The value of **PM1** must be higher than the nominal evaporation temperature of the machine to avoid unwanted high evaporation pressure protection actions.

The action on the electronic valve is not intended to eliminate the failure, but to keep the evaporation temperature below the threshold value.

The failure will only be resolved by decreasing the refrigeration load request.

During the action of the high evaporation pressure protection, overheating regulation is disabled to allow the electronic valve to limit the evaporation temperature.

The following chart shows the tripped high evaporation pressure protection:

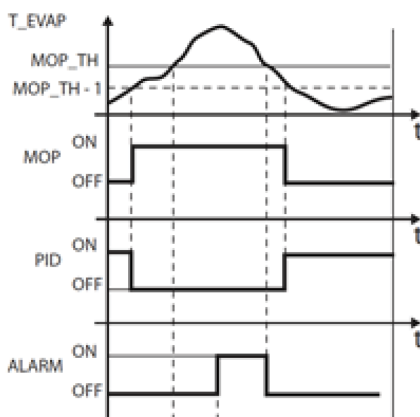

Quantity	Description
T_EVAP	Evaporation temperature
MOP	High evaporation pressure protection
MOP_TH	High evaporation pressure protection threshold. Parameter: PM1
PID	Overheating PID control
ALARM	Alarm
D	Alarm delay. Parameter: PM3
t	Time

8.13 Cold room light and door micro switch parameters



dOL

8.13.1 List of parameters

Parameter	Description	Options	Unit of measurement	Range	Default (*)
d d n	Selects the Door Micro Switch management	0 - Door Micro Switch Management disabled 1 - Compressor OFF / Fan Evap. OFF when the door is open 2 - Compressor OFF / Fan Evap. ON when the door is open 3 - Compressor ON / Fan. Evap. OFF when the door is open 4 - Compressor ON / Fan Evap. ON when the door is open	-	0...4	1
E L d	Enables switching on the Cold room Light from the door micro switch	0 – No 1 – Yes	-	0...1	1
d C d	Compressor switch-off delay with Door Open	-	min	0...999	1
d E d	Evaporator Fans switch-off delay with Door Open	-	min	0...999	0
d R d	Door Open signal delay	-	s	0...999	0
d S d	Cold room Light switch-off delay after Door closure	-	s	0...999	0

Note (*): LV and TN parameters the same except where indicated.

8.14 Parameters of the alarms

8.14.1 Alarm parameters from the inputs



ALM > IN

Alarm parameters from analogue inputs

Parameter	Description	Options	Unit of measurement	Range	Default (*)
R 0 1	Enables Discharge Probe High Temperature Alarm (STH)	0 - No 1 - Yes	-	0...1	0
R 0 2	Discharge Probe High Temperature Alarm Delay (STH)	-	min	0...999	0
R 0 3	Discharge Probe High Temperature Alarm Threshold (STH)	-	°C/°F	-99.9...99.9	99.9
R 0 4	Discharge Probe High Temperature Alarm Differential (STH)	-	K/°F	0.0...99.9	10

Parameter	Description	Options	Unit of measurement	Range	Default (*)
R05	Enables Ambient Probe High Temperature Alarm (STA)	0 - No	-	0...1	0
		1 - Yes			
R06	Ambient Probe High Temperature Alarm Delay (STA)	-	min	0...999	0
R07	Ambient Probe High Temperature Alarm Threshold (STA)	-	°C/°F	-99.9...99.9	50
R08	Ambient Probe High Temperature Alarm Differential (STA)	-	K/°F	0.0...99.9	5
R09	Enables Ambient Probe Low Temperature Alarm (STA)	0 - No	-	0...1	0
		1 - Yes			
R10	Ambient Probe Low Temperature Alarm Delay (STA)	-	min	0...999	0
R11	Ambient Probe Low Temperature Alarm Threshold (STA)	-	°C/°F	-99.9...99.9	-50
R12	Ambient Probe Low Temperature Alarm Differential (STA)	-	K/°F	0.0...99.9	5

Note (*): LV and TN parameters the same except where indicated.

Alarm parameters from digital inputs

Parameter	Description	Options	Unit of measurement	Range	Default (*)
PE_n	Maximum number of High Pressure Switch Alarms (PSH) from Digital Inp.	-	-	0...999	3
PE₁	Count interval of alarms from High Pressure Switch (PSH)	-	min	0...180	90
R17	External Alarm Delay (ExternalAlarm) from Digital Inp.	-	s	0...999	0

Note (*): LV and TN parameters the same except where indicated.

Alarm parameters for broken probes

Parameter	Description	Options	Unit of measurement	Range	Default (*)
R19	Enables Ambient temperature probe Fault/Broken Alarm (STA)	0 - No	-	0...1	0
		1 - Yes			
R20	Enables Liquid temperature probe Fault/Broken Alarm (STLIQ)	0 - No	-	0...1	0
		1 - Yes			
R21	Enables Humidity probe Fault/Broken Alarm (SHUM)	0 - No	-	0...1	0
		1 - Yes			
R22	Enables General probe 1 Fault/Broken Alarm (SG1)	0 - No	-	0...1	0
		1 - Yes			
R23	Enables General probe 1 Fault/Broken Alarm (SG2)	0 - No	-	0...1	0
		1 - Yes			

Note (*): LV and TN parameters the same except where indicated.

8.14.2 Operation alarm parameters

 ALM > OP

Alarm parameters for open door

Parameter	Description	Options	Unit of measurement	Range	Default (*)
d 0 d	Open Door Alarm Delay	-	min	0...999	30

Note (): LV and TN parameters the same except where indicated.*

Cold room regulation high temperature alarm parameters

Parameter	Description	Options	Unit of measurement	Range	Default (*)
R 5 1	High Regulation Temperature Alarm Delay at start-up	-	min	0...999	720
R 5 2	High Regulation Temperature Alarm Delay during regulation	-	min	0...999	15
R 5 3	High Regulation Temperature Alarm Delay during Open Door Alarm	-	min	0...999	15
R 5 4	High Regulation Temperature Alarm Delay with Door Open	-	min	0...999	5
R 5 5	High Regulation Temperature Alarm Delay from Defrost start-up	-	min	dS1...999	60
R 5 6	Selects the High Regulation Temperature Alarm mode	0 – Disabled 1 – Relative 2 – Absolute	-	0...2	1
R 5 7	High Regulation Temperature Alarm resolution differential	-	K/°F	0...99.9	2
R 5 8	Threshold (Absolute)/Differential (Relative) for High Regulation Temperature Alarm	-	°C/°F	-99.9...99.9	10

Note (): LV and TN parameters the same except where indicated.*

Cold room regulation low temperature alarm parameters

Parameter	Description	Options	Unit of measurement	Range	Default (*)
R 5 9	Low Regulation Temperature Alarm Delay	-	min	0...999	0
R 6 0	Selects the Low Regulation Temperature Alarm mode	0 – Disabled 1 – Relative 2 – Absolute	-	0...2	1
R 6 1	Low Regulation Temperature Alarm Differential	-	K/°F	0...99.9	2
R 6 2	Threshold (Absolute)/Differential (Relative) for Low Regulation Temperature Alarm	-	°C/°F	-99.9...99.9	5

Note (): LV and TN parameters the same except where indicated.*

Low regulation suction pressure alarm parameters

Parameter	Description	Options	Unit of measurement	Range	Default (*)
R 6 3	Selects priority for Low Regulation Suction Pressure Alarm	0 – Read only 1 – Serious Alarm	-	0...1	0
R 6 4	Delay for Low Regulation Suction Pressure Alarm	-	s	0...999	300
R 6 5	Low Regulation Suction Pressure Alarm Threshold	-	bar/psi	-99.9...99.9	NT: 1.4 LT: 0.3
R 6 6	Low Regulation Suction Pressure Alarm Differential	-	bar/psi	0...99.9	NT: 0.2 LT: 0.1

Note (*): LV and TN parameters the same except where indicated.

8.14.3 HACCP alarm parameters

 **ALM > HCP**

Parameter	Description	Options	Unit of measurement	Range	Default (*)
H C E	Enables HACCP Alarms	0 - No 1 - Yes	-	0...1	0
H S P	Selecting the probe for HACCP Alarms	1 - HACCP Probe 2 - Cold room Regulation Probe 3 – Average between the previous options	-	1...3	2
H C 1	Selecting the type of Alarm Threshold for HACCP High Temperature	0 - Relative 1 - Absolute	-	0...1	0
H C 2	HACCP High Temperature Alarm Delay	-	min	0...120	30
H C 3	HACCP High Temperature Alarm Delay Threshold	-	°C/°F	-99.9...99.9	20
H C 4	HACCP High Temperature Alarm Differential	-	K/°F	0...99.9	2
H C 5	HACCP High Temperature Alarm Threshold after Blackout	-	°C/°F	-99.9...99.9	20

Note (*): LV and TN parameters the same except where indicated.

Note: The HACCP alarms in this application do not replace monitoring and logs as required by law, but are a useful tool for improving the operation of the packaged unit.

Note: parameter **HC1** can only be changed if parameter **HSP** = 3, in all other cases, its value is set automatically.

8.14.4 Parameter HSP

Triggering of the HACCP high temperature alarm can be managed in three different ways thanks to the **HSP** parameter:

- **HSP = 1:** HACCP probe. The HACCP high temperature alarm is triggered with a delay set in parameter **HC2**, when the temperature recorded by the HACCP probe exceeds the value of threshold **HC3**.
- **HSP = 2:** Cold room regulation probe. The HACCP high temperature alarm is triggered with a delay set in parameter **HC2**, when the temperature recorded by the cold room regulation probe exceeds the high temperature threshold and remains so for a time equal to the sum of the **HC2** value with the cold room high temperature delay.

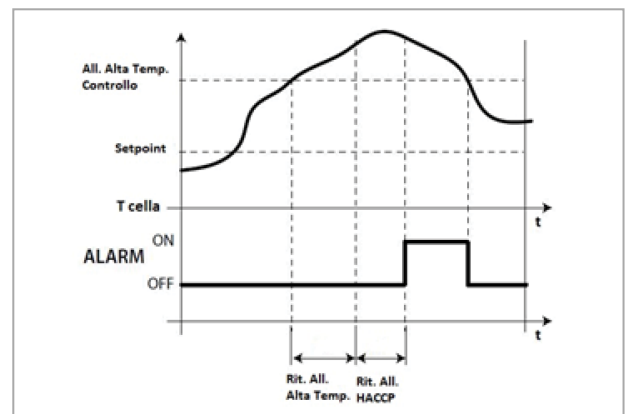
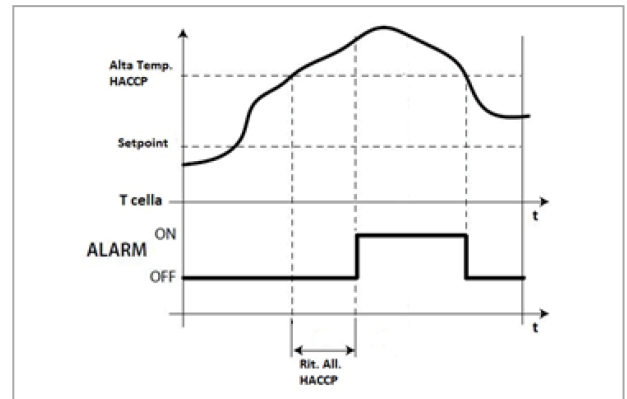

- **HSP = 3:** average between the HACCP probe and the cold room regulation probe. With **HSP = 3**, the temperature value that triggers the alarm is obtained by finding the average between the value detected by the HACCP probe and that of the cold room regulation probe. The delay time is set with **HC2**.

8.14.5 Parameter HC5

It is the cold room temperature threshold to be compared to the temperature value when the power supply is restored following a blackout. If the temperature inside the cold room is higher than that set in parameter **HC5**, the HACCP high temperature alarm is triggered.

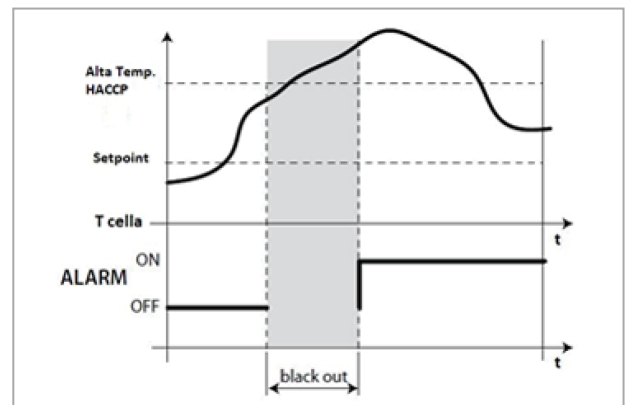

8.14.6 Alarm setting parameters

 **ALM > ALS**

Parameter	Description	Options	Unit of measurement	Range	Default (*)
ALB	Enables Buzzer on Display	0 - No	-	0...1	1
		1 - Yes			
rAL	Resets Alarm logs	0 - No	-	0...1	-
		1 - Yes			

Note (*): LV and TN parameters the same except where indicated.

8.15 General function parameters

8.15.1 List of general alarm parameters

 **GEF > ALF**

Parameter	Description	Options	Unit of measurement	Range	Default (*)
EG4	Enables General Alarm 1	0 - No	-	0...1	0
		1 - Yes			
AA1	Selects the variable for the regulation of General Alarm 1	Selectable variables (**)	-	1...40	1
AC1	Selects the enabling condition for General Alarm 1	1 - Always	-	1...5	1
		2 - Only during ON status			
		3 - Only during COOLING status			
		4 - Only during ALARM status			
		5 - Only during DEFROST status			
rIR	Selects the type of Direct/Reverse regulation for General Alarm 1	0 - Direct	-	0...1	0
		1 - Reverse			
ALI	Threshold for General Alarm 1	-	-	-99.9...99.9	0
dA1	Differential for General Alarm 1	-	-	0...99.9	0
Ad1	Delay for General Alarm 1	-	s	0...999	0
EG5	Enables General Alarm 2	0 - No	-	0...1	0
		1 - Yes			
AA2	Selects the variable for the regulation of General Alarm 2	Selectable variables (**)	-	1...40	1

Parameter	Description	Options	Unit of measurement	Range	Default (*)
AC2	Selects the enabling condition for General Alarm 2	1 – Always	-	1...5	1
		2 – Only during ON status			
		3 – Only during COOLING status			
		4 – Only during ALARM status			
		5 – Only during DEFROST status			
r2A	Selects the type of Direct/Reverse regulation for General Alarm 2	0 – Direct	-	0...1	0
		1 – Reverse			
AL2	Threshold for General Alarm 2	-	-	-99.9...99.9	0
dR2	Differential for General Alarm 2	-	-	0...99.9	0
Ad2	Delay for General Alarm 2	-	s	0...999	0

Note (*): LV and TN parameters the same except where indicated.

Note ()**: selectable variables

1 - Cold room 1 Temperature Probe	11 – Ambient Temperature Probe	21 – Regulation Suction Pressure Probe	31 – Thermal Protection Compressor 1 Input
2 – Evaporator Temperature Probe 1	12 – Suction Temperature Probe	22 – Regulation Condensing Pressure Probe	32 – Thermal Protection Compressor 2 Input
3 - Cold room 2 Temperature Probe	13 – Discharge Temperature Probe	23 – Cold Regulation Temperature Probe	33 – Thermal Protection Compressor 3 Input
4 – Evaporator Temperature Probe 2	14 – Liquid Temperature Probe	24 – Cooling Demand	34 – Door micro switch Input
5 – Suction Pressure Probe Circuit 1	15 – Evaporation Temperature Probe	25 – Heating Demand	35 – Remote On/Off Input
6 – Condensing Pressure Probe Circuit 1	16 – Evaporator Pressure Probe	26 – Compressor Demand	36 – Energy Saving Command Input
7 – Suction Pressure Probe Circuit 2	17 – HACCP Temperature Probe	27 – Condensing Demand	37 – Not Used
8 – Condensing Pressure Probe Circuit 2	18 – Humidity Probe	28 – Safety High Pressure Switch Input	38 – External Serious Alarm Input
9 – Suction Pressure Probe Circuit 3	19 – Generic Probe 1	29 – Safety Low Pressure Switch Input	39 – General Input 1
10 – Condensing Pressure Probe Circuit 3	20 - Generic Probe 2	30 – Pump-Down Pressure Switch Input	40 - General Input 2

8.15.2 Parameters to set general alarms

Up to two general alarms can be set by specifying the following for each:

- enabling
- chosen alarm variable
- enabling conditions
- type of alarm
- alarm threshold
- alarm differential
- alarm delay

8.16 General setting parameters

8.16.1 List of clock parameters (Real time clock)

 StG > rtC

Parameter	Description	Options	Unit of measurement	Range	Default (*)
r t c	RTC clock setting	-			

Note ()*: LV and TN parameters the same except where indicated.

8.16.2 List of supervision parameters

 StG > bMS

Parameter	Description	Options	Unit of measurement	Range	Default (*)
d E R	Serial address for BMS port	-	-	0...255	1
b d r	Baudrate for BMS port	0 - 1200	-	0...9	4
		1 - 2400			
		2 - 4800			
		3 - 9600			
		4 - 19200			
		5 - 38400			
		6 - 57600			
		7 - 76800			
		8 - 115200			
b t S	Bit Stop for BMS port	1 - 1	-	1...2	1
		2 - 2			
P A r	Parity for BMS port	0 - None	-	0...2	0
		1 - Odd			
		2 - Even			

Note ()*: LV and TN parameters the same except where indicated.

8.16.3 List of master/slave parameters

 StG > nEt

Parameter	Description	Options	Unit of measurement	Range	Default (*)
L 0 0	Selects the Master or Slave mode	1 – Master	-	1...2	1
		2 – Slave			
L 0 1	Address for Slave mode	-	-	1...9	1
L 0 2	Number of Slave devices for Master mode		-	0...9	0

Parameter	Description	Options	Unit of measurement	Range	Default (*)
L 03	Slave alarm view management in the Master unit	1 – No Slave alarm	-	1...3	3
		2 – Slave alarm view			
		3 – Slave alarm view and using Alarm relays			
L 04	Enables Setpoint from Master	0 – No	-	0...1	0
		1 – Yes			
L 05	Selects Network Probe	1 – No Network Probe	-	1...3	1
		2 – Temperature regulation probe from Master			
		3 – Average of the Temperature regulation Probes of all the units available in the network			
L 06	Selects management of the Cooling Request	1 – No Management	-	1...3	1
		2 – Simultaneous start-up of all the units			
		3 – Sequential start-up of the units			
L 07	Delay time between switching on the units with sequential start-up	-	s	0...999	10
L 08	Selects the Defrost management for Master/Slave	1 – No Management	-	1...5	3
		2 – Simultaneous start-up and independent end			
		3 – Simultaneous Start-up and end			
		4 – Sequential start-up			
		5 – Sequential start-up and no active cooling request			
L 09	Enables Serious Alarm from Master to the Slave Devices	0 – No	-	0...1	0
		1 – Yes			
L 10	Enables Door management from Master to the Slave Devices	0 – No	-	0...1	1
		1 – Yes			
L 11	Selects Display view of all the Slave devices	1 – No Management	-	1...3	2
		2 – View value /t1 + Icons			
		3 – View value /t1			
L 12	Enables ON/OFF command from Master to the Slave devices	0 – No	-	0...1	1
		1 – Yes			
L 13	Enables the Manual Defrost command from Master to the Slave devices	0 – No	-	0...1	1
		1 – Yes			
L 14	Enables the Cold room Light Switch-On from Master to the Slave devices	0 – No	-	0...1	1
		1 – Yes			
L 15	Enables Energy Saving command from Master to the Slave devices	0 – No	-	0...1	1
		1 – Yes			

Note (*): LV and TN parameters the same except where indicated.

Master/slave network

Up to 10 packaged units can be connected in master/slave configuration: 1 master + 9 slave.

Below are the parameters that define the master and the slave devices and the parameters that allow the master to control certain important functions of the slave devices:

Parameter	Description	Master setting	Slave setting
L00	Defines the master and slave devices	1	2
L01	Slave addresses	-	From 1 to 9
L02	Number of slave devices connected	from 1 to 9	-

If a slave controlled by a master remains isolated from the network, the operating parameters are those set locally. They will revert to those of the master when the connection is restored.

Centralised management via the master is recommended for all master/slave configurations.

Below is an example of a master/slave configuration:

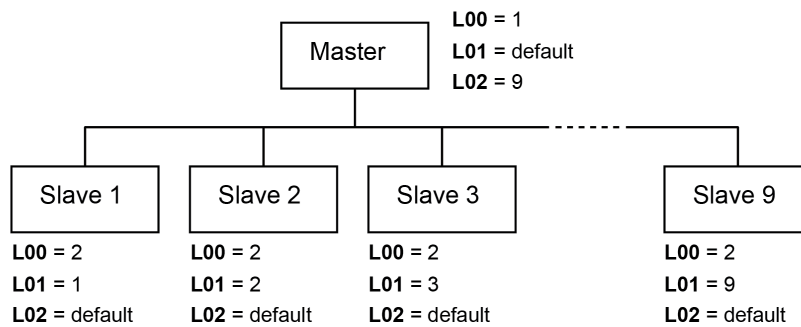

8.16.4 Password change parameters

StG > PwD

Parameter	Description	Options	Unit of measurement	Range	Default (*)
P 5 1	Setting the new Password for the User profile	-	-	0...9999	2201
P 5 2	Setting the new Password for the BEST Installer profile	-	-	0...9999	2300

Note (*): LV and TN parameters the same except where indicated.

8.16.5 Initialization parameters

StG > InI

Parameter	Description	Options	Unit of measurement	Range	Default (*)
r t n	Deletes Retain Memory	0 – No	-	0...1	0
		1 – Yes			
n u r	Deletes NVRAM Memory	0 – No	-	0...1	0
		1 – Yes			
r E S	Resets the Factory-set parameters (default settings)	0 – No	-	0...1	0
		1 – Yes			
n u i	Start new Wizard	0 – No	-	0...1	0
		1 – Yes			

Note (*): LV and TN parameters the same except where indicated.

8.16.6 Unit of measurement parameters

 StG > UOM

Parameter	Description	Options	Unit of measurement	Range	Default (*)
UN1	Selecting the unit of measurement for Display view	0 - No	-	0..6	6
		1 - S.I.			
		2 - USA			
		3 - UK			
		4 - Canada			
		5 - Lon			
UN2	Selecting the unit of measurement for WEB view (BMS, APP, IOT)	0 - No	-	0..6	6
		1 - S.I.			
		2 - USA			
		3 - UK			
		4 - Canada			
		5 - Lon			
	6 - S.I. (bar)				

Note (*): LV and TN parameters the same except where indicated.

9. Maintenance

This section includes the following topics:

9.1 Maintenance warnings	62
9.2 Periodic maintenance	63
9.3 Corrective maintenance	63
9.4 Checking or replacing condensing unit components	64
9.5 Remove the cover of the evaporating part	66
9.6 Checking or replacing evaporating part components	67
9.7 Check or replace components of the electrical box	68

9.1 Maintenance warnings

9.1.1 Required skills

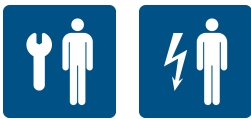

9.1.2 Safety



! DANGER!

Explosion/Burn. Presence of flammable gas. During maintenance, adopt all the precautions required by legislation in force and the warnings for adjustments and maintenance indicated in this instruction manual.

Low temperatures. During maintenance in the cold room, take breaks to avoid long exposure to low temperatures.

- Only perform the maintenance described in this instruction manual and observe the indicated maintenance frequency.
- Before carrying out any type of operation, it is necessary to check for propane leaks (R290) with a special gas detector.
- The machines have a factory-sealed refrigerant circuit. At the end of any type of operation that involves the removal/replacement of the gas, it is necessary to seal the circuit hermetically, restoring the factory conditions.
- Failure to reposition the guards at the end of maintenance can cause serious damage. Always refit the guards at the end of maintenance.
- At the end of maintenance, check that there are no tools or components left inside the packaged unit.
- Do not release the products used during maintenance into the environment. Follow the regulations in force regarding the disposal of dangerous and/or polluting fluids.

9.1.3 Isolation from energy sources

Before performing maintenance, disconnect the power plug.

9.1.4 Maintenance on equipment components



Perform maintenance by following the instructions, frequencies and all indications in the manuals and in the attached documentation. If necessary, contact RIVACOLD srl assistance.

9.2 Periodic maintenance

9.2.1 Required skills



9.2.2 Safety

	Always wear helmets, footwear and protective gloves.
	Always wear the mask and protective goggles.

9.2.3 Monthly operations

Task	Component	Procedure	Indicative time [min]
Check	Joinery	<ul style="list-style-type: none"> Check that all metal surfaces are in good condition Check that the screws are tightened correctly 	10
	Electrical cables	Check that the electrical cables are intact. If any cuts or cracks are found, immediately replace the power cable with a new one.	15
	Refrigeration circuit	Check that the refrigeration circuit is in good condition and that there are NO refrigerant gas leaks. Usually, the presence of lubricating oil indicates leaking refrigerant from the circuit. If in doubt, before carrying out any operation, contact RIVACOLD srl.	30
Cleaning	Evaporator and condenser	Clean as follows: <ul style="list-style-type: none"> as needed if dust or grease is noted 	15

9.2.4 Operations every four months

Task	Component	Procedure
Checks, replacements	Electrical box	Check the contactors and replace them if they show signs of deterioration.
	Compressor	Check the noise (see "Check the compressor noise" on page 65)
Cleaning	Electrical box	Clean the fixed and mobile contacts of all the contactors.

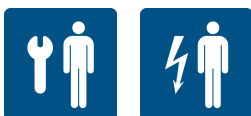

9.3 Corrective maintenance

9.3.1 Required skills



9.3.2 Safety

If in doubt, before carrying out any operation, contact RIVACOLD srl.

	Always wear helmets, footwear and protective gloves.
	Always wear the mask and protective goggles.

9.3.3 What to do

In case of damage or a malfunction, consult "Installation and operation troubleshooting" on page 70 or Rivacold srl

9.4 Checking or replacing condensing unit components

9.4.1 Required skills



9.4.2 When to check or replace

Perform this procedure when problems are found on the condensing unit components (see "Installation and operation troubleshooting" on page 70).

9.4.3 Warning

Check or replace the components following the instructions, frequency and all indications in this manual and in the attached documentation. If necessary, contact RIVACOLD srl assistance.

9.4.4 Checking or replacing internal components of the condensing unit

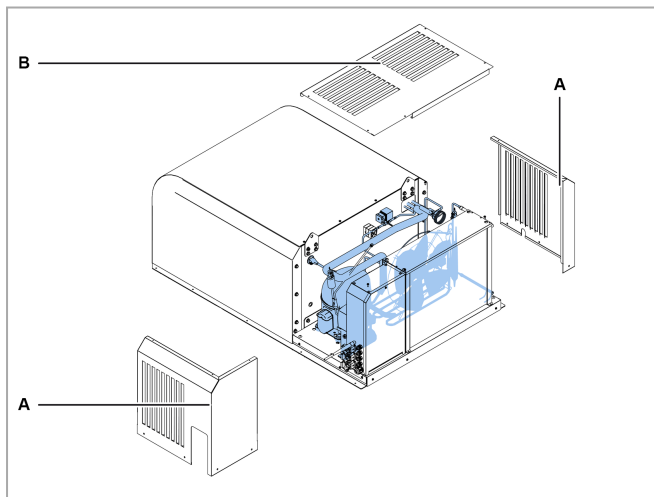

1. Remove the side panels **[A]**.
2. Remove the panel of the condensing unit part **[B]**.
3. Check or replace the internal components of the condensing unit.
4. Set all the panels in place again.

9.4.5 Replace the thermostatic valve

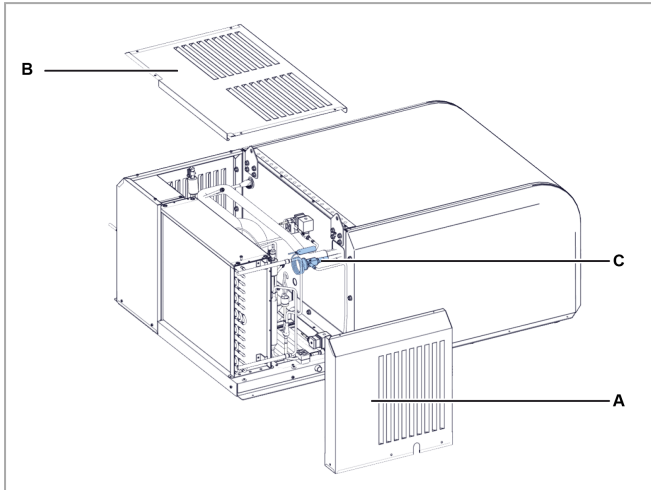

Remove the right side panel **[A]** and the top panel **[B]**, check and, if necessary, replace the thermostatic valve **[C]**.

9.4.6 Checking or replacing the condensing fan unit

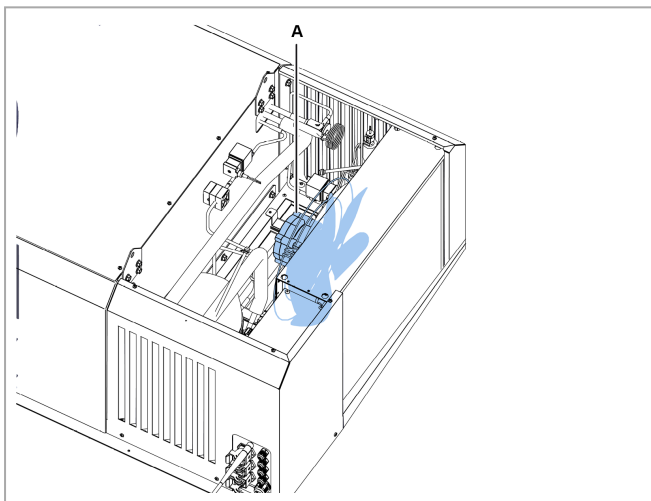

1. Remove the top panel.
2. Check or replace the fan unit of the evaporating part **[A]**.
3. Replace the damaged component with an original spare part and follow the enclosed instructions.
4. Set the panel back in place.

9.4.7 Check the condensate drain tray

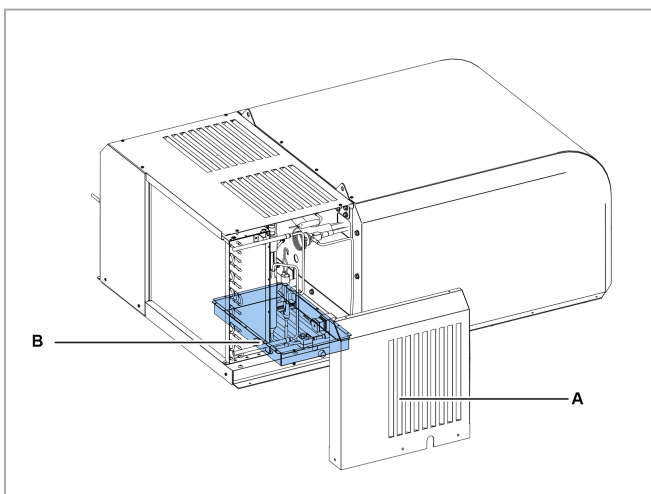

1. Remove the right side panel **[A]**
2. Check the condensate drain tray **[B]**.
3. Set the panel back in place.

9.4.8 Check the compressor noise

1. Turn the packaged unit on.
2. Verify that the compressor does NOT generate vibrations or clicking sounds, that is, sounds generated by short, close, sharp and frequent blows.

3. If the compressor emits or generates vibrations or clicking sounds, it could be broken and must be replaced (see "Replace the compressor" below), or there is mechanical clearance between the parts that must be fixed.

9.4.9 Replace the compressor

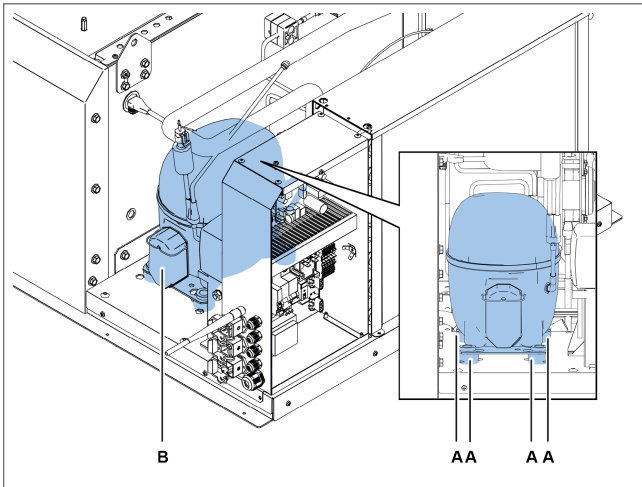

1. Remove left side panel and top panel.
2. Undo the screws [A] and remove the compressor [B], removing all the components that prevent its removal.
3. Insert the new compressor, securing it with the screws and put all the other components back in place.
4. Set all the panels in place again.

9.4.10 Replace compressor electrical box

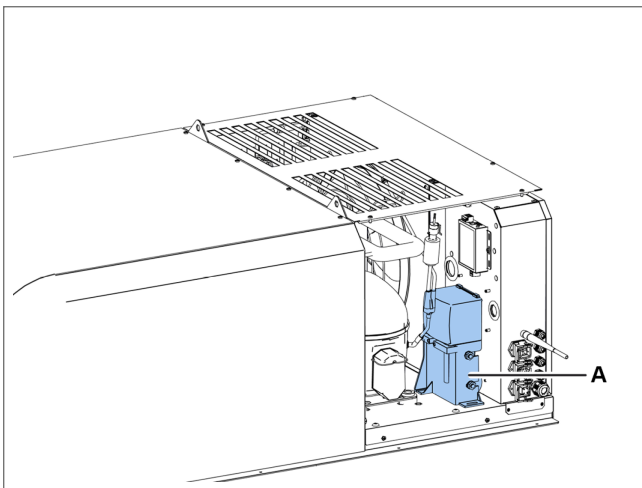

1. Remove left side panel and top panel.
2. Remove the compressor electrical box [A], removing all the components that prevent its removal.
3. Insert the new compressor housing and replace all other components.
4. Set all the panels in place again.

9.5 Remove the cover of the evaporating part

9.5.1 Required skills



9.5.2 Procedure

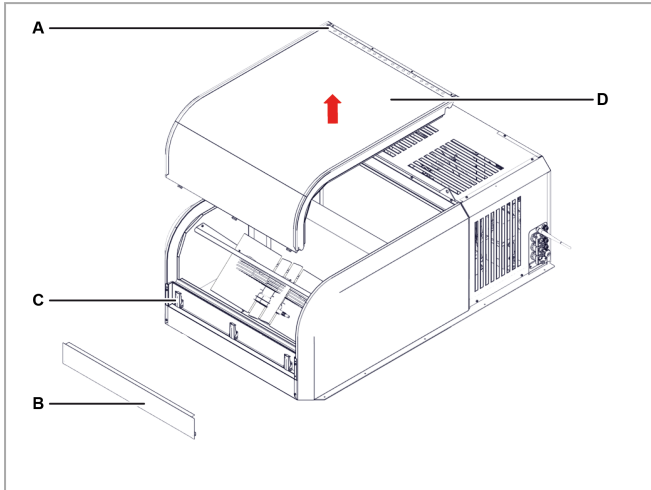

Undo the screws **[A]**, remove the magnetic panel **[B]**, open the snap-on clamps **[C]** and remove the cover of the evaporating part **[D]**.

9.6 Checking or replacing evaporating part components

9.6.1 Required skills



9.6.2 When to check or replace

Perform this procedure when problems are found on the evaporating part components (see "Installation and operation troubleshooting" on page 70).

9.6.3 Warning

Check or replace the components following the instructions, frequency and all indications in this manual and in the attached documentation. If necessary, contact RIVACOLD srl assistance.

9.6.4 Checking or replacing the fan unit

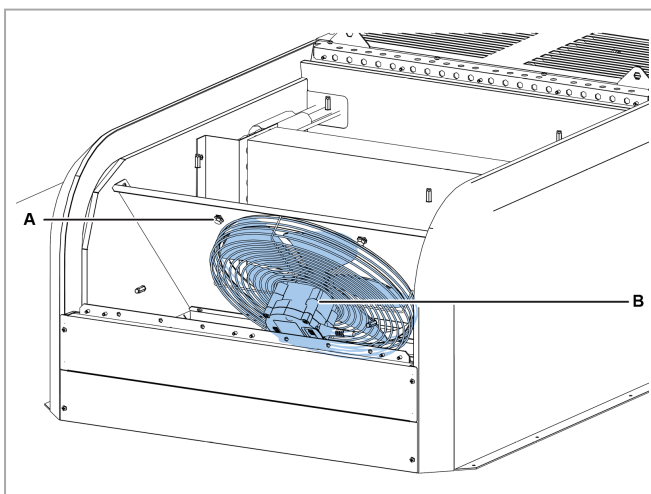

1. Remove the cover of the evaporating part (see "Remove the cover of the evaporating part" on the previous page).
2. Undo the grid screws **[A]**.
3. Check and if necessary replace the evaporating part's fan unit **[B]** with an original spare part and follow the enclosed instructions.
4. Tighten the grid screws and replace the cover of the evaporating part.

9.6.5 Checking or replacing components

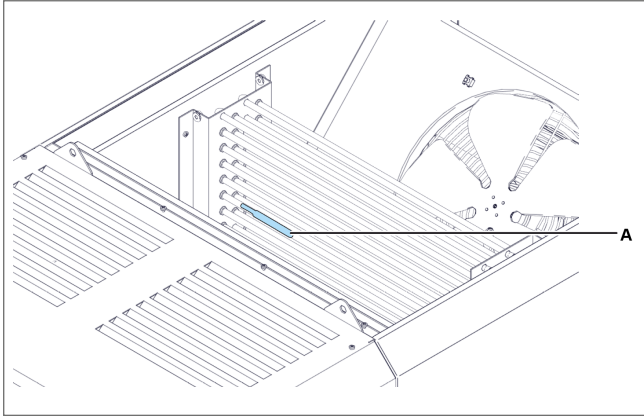

1. Check or replace the fin coil temperature probe **[A]**.

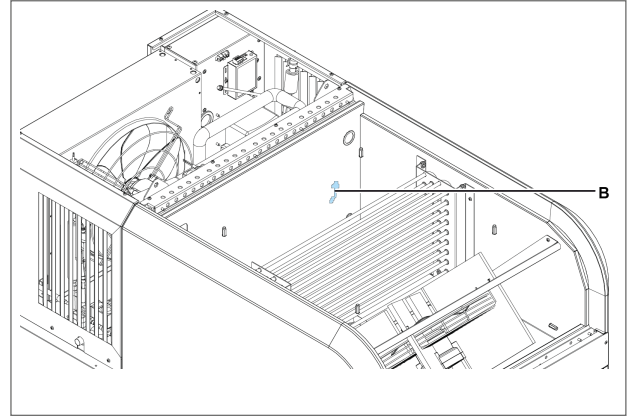

2. Check or replace the cold room temperature probe **[B]**.

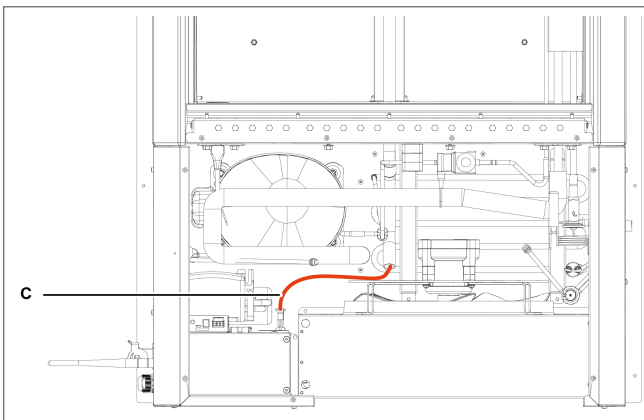

3. Check or replace the drain heater **[C]**.

9.7 Check or replace components of the electrical box

9.7.1 Required skills



9.7.2 When to check or replace

Perform this procedure when problems are found on the electrical box components (see "Installation and operation troubleshooting" on page 70).

9.7.3 Warning

Check or replace the components following the instructions, frequency and all indications in this manual and in the attached documentation. If necessary, contact RIVACOLD srl assistance.

9.7.4 Access the electrical box

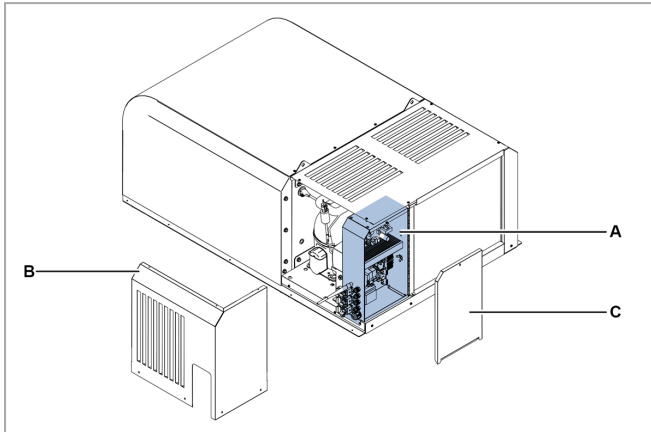

1. Access the electrical box components **[A]** by removing the left side panel **[B]** and the electrical box panel **[C]**.
2. Check or replace the component.

10. Diagnostics

This section includes the following topics:

10.1 Installation and operation troubleshooting	70
10.2 Errors indicated by the controller	72

10.1 Installation and operation troubleshooting

10.1.1 Skills

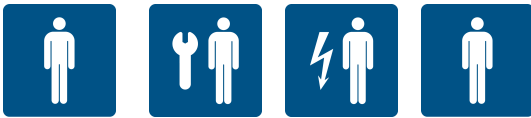

COMPANY

10.1.2 Safety warnings

If maintenance is required, follow the instructions and all indications in this manual and in the attachments. If necessary, contact RIVACOLD srl assistance.





In case of maintenance, wear helmets, footwear and protective gloves.

10.1.3 Causes and solutions





The packaged unit does not start-up

Cause	Solution	Personnel
Power failure	<ul style="list-style-type: none"> Check the connection to the mains Check that there is voltage on the electrical mains and that it conforms to the rated data Check the state of the circuit breakers on the machine Check the correct connection of the display 	
The compressor's thermal protection has tripped	Check the integrity and activation state of the compressor circuit breaker on the machine and, if present, the thermal protection on the compressor	
The start condenser is faulty	Replace the start condenser.	
No controller consent to the compressor	<ul style="list-style-type: none"> Check the Setpoint (Set) and the differential (diF). Load the default setting of the unit. 	
Controller consent is present but the compressor is off (OFF)	<ul style="list-style-type: none"> Check the wiring of the compressor relay on the circuit board and its activation state. If the relay is NOT active, replace the circuit board Check the wiring of the compressor power relay on the electrical box and its activation state. If the relay is NOT active, replace it 	
The electric motor has an interrupted or short-circuited winding	Replace the compressor.	

The compressor is running without consent

Cause	Solution	Personnel
The compressor relay is stuck to the circuit board	Replace the circuit board	
The compressor power relay is stuck to the electrical box	Replace the compressor power relay	





The packaged unit runs continuously or for long periods

Cause	Solution	Personnel
The packaged unit does NOT reach the Setpoint temperature and the evaporator fans DO NOT work	<ul style="list-style-type: none"> • If there is NO controller consent, check the evaporator fan parameters and, if necessary, load the default setting. • If there is controller consent, then, check the wiring of the fans and the relay on the circuit board and its activation state. • If the relay is NOT active, replace the circuit board 	 
The packaged unit does NOT reach the Setpoint temperature	<ul style="list-style-type: none"> • If the evaporator is blocked with ice, then manually activate the defrost several times (see "Control panel operations" on page 17) until it is completely cleaned • If the condenser is dirty, clean it • Check that the unit is sized correctly for the required thermal load 	   COMPANY

The condensation water CANNOT evaporate

Cause	Solution	Personnel
The condensing temperature is too low	Activate the limitation of the minimum condensing temperature, modify the CoM parameter, bringing it to 2, i.e. air condensing management with On/Off to prevent the condensation from dropping too much	

The suction pipe and the compressor are frosted

Cause	Solution	Personnel
There is a liquid return and the evaporator fans are NOT working	<ul style="list-style-type: none"> If there is NO controller consent, check the evaporator fan parameters and, if necessary, load the default setting. If there is controller consent, then, check the wiring of the fans and the relay on the circuit board together with its activation state. If the relay is NOT active, replace the circuit board 	 
Liquid return	Check the overheating value in the evaporator inside the cold room. If the value is less than 2K, then the thermostatic valve does NOT work and is blocked in the open position and, therefore, must be replaced	 

10.2 Errors indicated by the controller

10.2.1 Skills



COMPANY

10.2.2 Errors

Legend (*): A = automatic; M = manual; S = semi-automatic.

ID	Description	Cause	Impact	Resolution	Reset (*)	Relay
Err	HMI communication error	Connection error between the circuit board and HMI	User interface not usable	Check the electrical connections or replace the interface, if necessary	A	No
Etc	Display/keyboard communication error	Connection error between Display and Keyboard	User interface not usable	Check connection between Display and Keyboard replace interface if necessary	A	No
0	Retain memory writing number error	Fault in the memory of the electronic control	Machine stop due to circuit board fault	Replace the circuit board	M	No
1	Retain memory writing error	Fault in the memory of the electronic control	Machine stop due to circuit board fault	Replace the circuit board	M	No
2	Cold room temperature probe alarm	Value measured outside the operating ranges Faulty or disconnected sensor	Visual indication only	Check wiring and integrity of the probe and replace it if necessary	A	No
3	Evaporator temperature probe alarm	Value measured outside the operating ranges Faulty or disconnected sensor	Visual indication only	Check wiring and integrity of the probe and replace it if necessary	A	No

ID	Description	Cause	Impact	Resolution	Reset (*)	Relay
4	Cold room 2 temperature probe alarm	Value measured outside the operating ranges Faulty or disconnected sensor	Visual indication only, evaporator defrost carried out due to Time-out	Check wiring and integrity of the probe and replace it if necessary	A	No
5	Evaporator 2 temperature probe alarm	Value measured outside the operating ranges Faulty or disconnected sensor	Visual indication only, evaporator 2 defrost carried out due to Time-out	Check wiring and integrity of the probe and replace it if necessary	A	No
6	Circuit 1 Suction pressure probe alarm	Value measured outside the operating ranges Faulty or disconnected sensor	If the Leak Function is active, it causes circuit 1 to stop, otherwise only a visual indication is given	Check wiring and integrity of the probe and replace it if necessary	A	Yes
7	Circuit 1 condensing pressure probe alarm	Value measured outside the operating ranges Faulty or disconnected sensor	Visual indication only	Check wiring and integrity of the probe and replace it if necessary	A	No
8	Ambient temperature probe alarm	Value measured outside the operating ranges Faulty or disconnected sensor	Visual indication only. If the Floating Condensing function is enabled, parameter EFC=1 , this is disabled.	Check wiring and integrity of the probe and replace it if necessary	A	No
9	Suction temperature probe alarm	Value measured outside the operating ranges Faulty or disconnected sensor	Visual indication only	Check wiring and integrity of the probe and replace it if necessary	A	No
10	Discharge temperature probe alarm	Value measured outside the operating ranges Faulty or disconnected sensor	Visual indication only	Check wiring and integrity of the probe and replace it if necessary	A	No
11	Liquid temperature probe alarm	Value measured outside the operating ranges Faulty or disconnected sensor	Visual indication only	Check wiring and integrity of the probe and replace it if necessary	A	No
12	Evaporation temperature probe alarm	Value measured outside the operating ranges Faulty or disconnected sensor	Visual indication only	Check wiring and integrity of the probe and replace it if necessary	A	No
13	Evaporator pressure probe alarm	Value measured outside the operating ranges Faulty or disconnected sensor	Visual indication only	Check wiring and integrity of the probe and replace it if necessary	A	No
14	HACCP temperature probe alarm	Value measured outside the operating ranges Faulty or disconnected sensor	Visual indication only	Check wiring and integrity of the probe and replace it if necessary	A	No

ID	Description	Cause	Impact	Resolution	Reset (*)	Relay
15	General probe 1 alarm	Value measured outside the operating ranges Faulty or disconnected sensor	Visual indication only	Check wiring and integrity of the probe and replace it if necessary	A	No
16	General probe 2 alarm	Value measured outside the operating ranges Faulty or disconnected sensor	Visual indication only	Check wiring and integrity of the probe and replace it if necessary	A	No
17	Humidity probe alarm	Value measured outside the operating ranges Faulty or disconnected sensor	Visual indication only	Check wiring and integrity of the probe and replace it if necessary	A	No
18	High pressure switch alarm	High Pressure Switch alarm triggered, possible causes: Ambient temperature very high Condenser fans not functioning Condenser very dirty	Stopped machine with manual reset if trips are higher than the PEN parameter in a time interval less than the PEI parameter, otherwise automatic reset.	Check the ambient temperature of the place of installation Clean the condenser Check the operation of the condenser fan motor	S	Yes
19	Low pressure switch alarm	Low pressure switch alarm triggered, possible causes: Refrigerant leak Ice formation in the evaporating coil Broken evaporator fans	Stopped machine	Check that the evaporator fans function properly Check for ice in the evaporator coil Check the refrigerant charge of the unit	A	Yes
20	Compressor 1 alarm	Compressor 1 alarm triggered, possible causes: circuit breaker or dedicated thermal protector tripped Compressor overheating or short circuit	Circuit 1 block	Check the condition of the compressor	A	Yes
21	Compressor 2 alarm	Compressor 2 alarm triggered, possible causes: circuit breaker or dedicated thermal protector tripped Compressor overheating or short circuit	Circuit 2 block	Check the condition of compressor 2	A	Yes
22	External alarm	External alarm triggered	Stopped machine	Check the digital input configured with this alarm and the relative activating contact.	A	Yes

ID	Description	Cause	Impact	Resolution	Reset (*)	Relay
23	High discharge temperature alarm	High discharge temperature alarm triggered, possible causes: high overheating, high condensing temperature	Stopped machine	Check the condensing and overheating of the unit (gas charge)	A	Yes
24	High ambient temperature alarm	Ambient temperature above threshold A07	Visual indication only	Check that the detected temperature matches that displayed	A	Yes
25	Low ambient temperature alarm	Ambient temperature below threshold A11	Visual indication only	Check that the detected temperature matches that displayed	A	No
26	Generic digital input 1 alarm	Connected device tripped	Visual indication only	Check the condition of the configured Digital input	A	No
27	Generic digital input 1 alarm	Connected device tripped	Visual indication only	Check the condition of the configured Digital input	A	No
28	Open door timeout alarm	Door open for longer than parameter dOd	Machine restart according to user programming	Close the cold room door or check the door micro switch connection	A	No
29	Circuit 2 Suction pressure probe alarm	Value measured outside the operating ranges Faulty or disconnected sensor	If the Leak Function is active, it causes circuit 2 to stop, otherwise only a visual indication is given	Check wiring and integrity of the probe and replace it if necessary	A	No
30	Circuit 2 condensing pressure probe alarm	Value measured outside the operating ranges Faulty or disconnected sensor	Visual indication only	Check wiring and integrity of the probe and replace it if necessary	A	No
31	Circuit 3 Suction pressure probe alarm	Value measured outside the operating ranges Faulty or disconnected sensor	If the leak function is active, it causes circuit 3 to stop, otherwise only a visual indication is given	Check wiring and integrity of the probe and replace it if necessary	A	No
32	Circuit 3 condensing pressure probe alarm	Value measured outside the operating ranges Faulty or disconnected sensor	Visual indication only	Check wiring and integrity of the probe and replace it if necessary	A	No
33	Compressor 3 alarm	Compressor 3 alarm triggered, possible causes: circuit breaker or dedicated thermal protector tripped Compressor overheating or short circuit	Circuit 3 block	Check the condition of compressor 3	A	Yes

ID	Description	Cause	Impact	Resolution	Reset (*)	Relay
34	Defrost not performed alarm	Evaporator temperature higher than the defrost end value	Defrost not performed, visual indication for 5 seconds and unit proceeds with its standard operating cycle	Check parameter dT1 or dT2	A	No
35	Blackout alarm	Power failure for more than 1 minute	Visual indication, if blackout lasts longer than parameter tb0 forced defrost starts	Check power source or electrical connections	M	No
36	Low overheating protection	Overheating too low, below threshold P7 for longer than P9	The valve closing intensity is increased: the more the overheating drops below the threshold, the greater the valve closing intensity will be. The LowSH threshold must be less than or equal to the overheating setpoint. The low overheating integral time indicates the intensity of the reaction: the lower it is, the greater the intensity of the reaction.	Check that the compressor, the thermostatic valve and the low pressure and suction temperature transducers function properly. Check parameters P7 , P8 , P9 .	A	No
37	Evaporation temperature low protection	Evaporating temperature too low, below threshold PL1 for longer than PL3	The valve opening intensity is increased. The further the temperature drops below the threshold, the greater the valve opening intensity will be. The integral time indicates the intensity of the action: the lower it is, the greater the intensity.	Check that the thermostatic valve and evaporator fans function properly. Check for ice on the evaporator coil. Check parameters PL1 , PL2 , PL3	A	No
38	High evaporation temperature protection	Evaporating temperature too high, above threshold PM1 for longer than PM3	Closing of the electronic valve in a controlled manner, which implies abandoning the overheating regulation, and its increase. The protection will therefore have a moderate reaction that tends to limit the increase in evaporation temperature, keeping it below the operating threshold, trying to increase the overheating as little as possible.	Cooling demand too high or check that the compressor and thermostatic valve function properly. Check parameters PM1 , PM2 , PM3	A	No
39	High condensing temperature protection	Condensing temperature too high	Moderate closure of the valve and relative increase in overheating	Check that the condenser-fan functions Clean the condensing coil	A	No
40	Low intake temperature alarm	Low suction temperature	Visual indication only		A	No

ID	Description	Cause	Impact	Resolution	Reset (*)	Relay
41	EEV motor error	Faulty valve motor or no connection	EEV valve regulation interrupted	Check the connections and the condition of the motor. Switch the circuit board off and back on	A	No
42	Ineffective adaptive control	Valve tuning failed	Visual indication only	Check the setting of parameter PrE	A	No
43	EEV emergency closure alarm	Power failure and valve closed in emergency due to power supply from an external source (Ultra-cap or UPS)	EEV valve regulation interrupted	Check the power supply of the circuit board	A	No
44	Error in the EEV range of parameters	Error in EEV Driver parameterization	Visual indication only	Check the parameters of the EEV unit	A	No
45	Error in the EEV service position percentage	Manual forcing value outside the 0-100% range	Interruption of manual valve forcing	Check the value of parameter PMu	A	No
46	EEV valve ID error	Error in EEV Driver parameterization	Visual indication only	Check parameters PVt and PVM	A	No
47	Circuit 1 gas leak alarm	Probable refrigerant leak in circuitry 1	Circuit 1 block	Check the circuitry and verify whether there is a refrigerant leak	M	Yes
48	Circuit 2 gas leak alarm	Probable refrigerant leak in circuitry 2	Circuit 2 block	Check the circuitry and verify whether there is a refrigerant leak	M	Yes
49	Circuit 3 gas leak alarm	Probable refrigerant leak in circuitry 2	Circuit 3 block	Check the circuitry and verify whether there is a refrigerant leak	M	Yes
50	HACCP alarm after blackout	After a blackout lasting more than one minute, the measured HACCP Temperature is above threshold HC5	Visual indication, event saved in the relative HACCP LOG and in the HACCP alarm log	Check the operating condition of the unit, whether the door is open or modify the tripping thresholds	A	No
51	HACCP alarm	HACCP temperature above the set threshold, parameter HC3 if HC1 =0 or alarm 53 if HC1 =1, for longer than HC2	Visual indication, event saved in the relative HACCP LOG and in the HACCP alarm log	Check the operating condition of the unit, whether the door is open or modify the tripping thresholds	A	No
52	High regulation temperature alarm	Regulation Temperature above the set threshold, parameter A58 if A56 =2 or SET+A58 if A56 =1.	Visual indication only	Check whether the regulation temperature is consistent with that measured and if necessary, modify tripping threshold A58	A	Yes
53	Low regulation temperature alarm	Regulation Temperature above the set threshold, parameter A62 if A56 =2 or SET+A62 if A56 =1.	Visual indication only	Check whether the regulation temperature is consistent with that measured and if necessary, modify tripping threshold A62	A	Yes

ID	Description	Cause	Impact	Resolution	Reset (*)	Relay
54	Pump-down stop alarm for maximum time	The compressor has made more than 5 pump-down stops in a time shorter than that given by the sum of parameters Cit - dOF - toP multiplied by 5, like the number of stops considered for the alarm.	Stopped machine	Check the pump-down stop threshold tPd and the relative differential dPd . Check for any liquid leak in the suction line.	A	Yes
55	Compressor general alarm	All the compressors in the unit are in alarm state	Stopped machine	Check the condition of the compressors in the unit	A	Yes
56	General gas leak alarm	Probable refrigerant leak in the unit circuitry or evaporator blocked with ice	Stopped machine	Check the circuitry and whether there is a leak or check the condition of the evaporator, probably blocked with ice	M	Yes
57	Regulation temperature probe alarm	Probe(s) used for regulation in alarm state	Stopped machine, emergency cycle starts if activated	Check probe alarms and verify their state and connections	A	Yes
58	Regulation suction pressure probe alarm	Probe(s) used for regulation in alarm state	Visual indication only, if the Leak function or parameter A63 =1 is enabled, the machine is stopped	Check probe alarms and verify their state and connections	A	Yes
59	Regulation condensing pressure probe alarm	Probe(s) used for regulation in alarm state	Condenser fans forcing at 100%. Visual indication only, if parameter A67 =1 and A71 =1 the machine is stopped	Check probe alarms and verify their state and connections	A	Yes
60	Evaporator fan regulation probe alarm	Probe(s) used for regulation in alarm state	Visual indication only, evaporator fans run continuously	Check probe alarms and verify their state and connections	A	No
61	Evaporator 2 fan regulation probe alarm	Probe(s) used for regulation in alarm state	Visual indication only, evaporator 2 fans run continuously	Check probe alarms and verify their state and connections	A	No
62	Regulation low suction pressure alarm	Suction Pressure below the threshold set in parameter A65	If parameter A63 =1 the machine is stopped, otherwise, visual indication only	Check whether the pressure in the circuit is consistent with what was measured. Check that the evaporator fans are working properly and that the evaporator pack is free of ice.	A	Yes
63	Regulation condensing high pressure alarm	Condensing pressure above the threshold set in parameter A69	Condenser fans forcing at 100%. If parameter A67 =1 the machine is stopped, otherwise, visual indication only	Check whether the pressure in the circuit is consistent with what was measured. Check that the condenser fan is working properly, that the condenser is clean and that the ambient temperature is within the machine's working range.	A	Yes

ID	Description	Cause	Impact	Resolution	Reset (*)	Relay
64	Regulation condensing low pressure alarm	Condensing pressure below the threshold set in parameter A73	If parameter A71 =1 the machine is stopped, otherwise, visual indication only	Check whether the pressure in the circuit is consistent with what was measured. Check that the ambient temperature is within the working range of the machine.	A	No
65	Safety defrost probe alarm	Probe(s) used for the safety defrost function in alarm state	Deactivation of the safety defrost function	Check probe alarms and verify their state and connections	A	No
66	General alarm probe 1 alarm	Probe(s) used for the generic function in alarm state	Deactivation of the generic function	Check probe alarms and verify their state and connections	A	No
67	General alarm probe 2 alarm	Probe(s) used for the generic function in alarm state	Deactivation of the generic function	Check probe alarms and verify their state and connections	A	No
68	General analogue output probe alarm	Probe(s) used for the generic function in alarm state	Deactivation of the generic function	Check probe alarms and verify their state and connections	A	No
69	General digital output probe 1 alarm	Probe(s) used for the generic function in alarm state	Deactivation of the generic function	Check probe alarms and verify their state and connections	A	No
70	General digital output probe 2 alarm	Probe(s) used for the generic function in alarm state	Deactivation of the generic function	Check probe alarms and verify their state and connections	A	No
71	Alarm on slave unit 1	Serious alarm in progress in slave unit 1	Slave unit in alarm state not considered by the master in the master/slave functions	Check the slave unit in alarm state and check the alarm in progress	A	Yes
72	Alarm on slave unit 2	Serious alarm in progress in slave unit 2	Slave unit in alarm state not considered by the master in the master/slave functions	Check the slave unit in alarm state and check the alarm in progress	A	Yes
73	Alarm on slave unit 3	Serious alarm in progress in slave unit 3	Slave unit in alarm state not considered by the master in the master/slave functions	Check the slave unit in alarm state and check the alarm in progress	A	Yes
74	Alarm on slave unit 4	Serious alarm in progress in slave unit 4	Slave unit in alarm state not considered by the master in the master/slave functions	Check the slave unit in alarm state and check the alarm in progress	A	Yes
75	Alarm on slave unit 5	Serious alarm in progress in slave unit 5	Slave unit in alarm state not considered by the master in the master/slave functions	Check the slave unit in alarm state and check the alarm in progress	A	Yes
76	Alarm on slave unit 6	Serious alarm in progress in slave unit 6	Slave unit in alarm state not considered by the master in the master/slave functions	Check the slave unit in alarm state and check the alarm in progress	A	Yes

ID	Description	Cause	Impact	Resolution	Reset (*)	Relay
77	Alarm on slave unit 7	Serious alarm in progress in slave unit 7	Slave unit in alarm state not considered by the master in the master/slave functions	Check the slave unit in alarm state and check the alarm in progress	A	Yes
78	Alarm on slave unit 8	Serious alarm in progress in slave unit 8	Slave unit in alarm state not considered by the master in the master/slave functions	Check the slave unit in alarm state and check the alarm in progress	A	Yes
79	Alarm on slave unit 9	Serious alarm in progress in slave unit 9	Slave unit in alarm state not considered by the master in the master/slave functions	Check the slave unit in alarm state and check the alarm in progress	A	No
80	Slave unit 1 offline	Probable incorrect connection or disconnection of the master/slave line	Slave unit in alarm state not considered by the master in the master/slave functions	Check the connection of the master/slave line or the parameters of the NET unit	A	No
81	Slave unit 2 offline	Probable incorrect connection or disconnection of the master/slave line	Slave unit in alarm state not considered by the master in the master/slave functions	Check the connection of the master/slave line or the parameters of the NET unit	A	No
82	Slave unit 3 offline	Probable incorrect connection or disconnection of the master/slave line	Slave unit in alarm state not considered by the master in the master/slave functions	Check the connection of the master/slave line or the parameters of the NET unit	A	No
83	Slave unit 4 offline	Probable incorrect connection or disconnection of the master/slave line	Slave unit in alarm state not considered by the master in the master/slave functions	Check the connection of the master/slave line or the parameters of the NET unit	A	No
84	Slave unit 5 offline	Probable incorrect connection or disconnection of the master/slave line	Slave unit in alarm state not considered by the master in the master/slave functions	Check the connection of the master/slave line or the parameters of the NET unit	A	No
85	Slave unit 6 offline	Probable incorrect connection or disconnection of the master/slave line	Slave unit in alarm state not considered by the master in the master/slave functions	Check the connection of the master/slave line or the parameters of the NET unit	A	No
86	Slave unit 7 offline	Probable incorrect connection or disconnection of the master/slave line	Slave unit in alarm state not considered by the master in the master/slave functions	Check the connection of the master/slave line or the parameters of the NET unit	A	No
87	Slave unit 8 offline	Probable incorrect connection or disconnection of the master/slave line	Slave unit in alarm state not considered by the master in the master/slave functions	Check the connection of the master/slave line or the parameters of the NET unit	A	No
88	Slave unit 9 offline	Probable incorrect connection or disconnection of the master/slave line	Slave unit in alarm state not considered by the master in the master/slave functions	Check the connection of the master/slave line or the parameters of the NET unit	A	No

ID	Description	Cause	Impact	Resolution	Reset (*)	Relay
89	Slave alarm offline	Probable incorrect connection or disconnection of the master/slave line	Slave unit in alarm state not considered by the master in the master/slave functions	Check the connection of the master/slave line or the parameters of the NET unit	A	No
90	Alarm from master	Serious alarm in progress in master unit	The master unit is blocked, the slave devices work independently with their own parameters	Check the master unit and check the alarm in progress	A	No
91	Evaporator defrost timeout alarm	Evaporator defrost ended due to maximum time and not due to temperature	Visual indication only	Check the defrost end value dT1 or the maximum duration value dS1	A	No
92	Evaporator 2 defrost timeout alarm	Evaporator defrost ended due to maximum time and not due to temperature	Visual indication only	Check the defrost end value dT2 or the maximum duration value dS2	A	No
93	Sequential defrost skipped on slave 1 alarm	Defrost cycle skipped on slave 1 during the sequential defrost stage due to missing conditions for longer than dT1 + tdc + dt + 1 minute (parameters of the master)	Defrost not performed, visual indication only	Check the conditions of the unit and if necessary, check parameter dT1	A	No
94	Sequential defrost skipped on slave 2 alarm	Defrost cycle skipped on slave 2 during the sequential defrost stage due to missing conditions for longer than dT1 + tdc + dt + 1 minute (parameters of the master)	Defrost not performed, visual indication only	Check the conditions of the unit and if necessary, check parameter dT1	A	No
95	Sequential defrost skipped on slave 3 alarm	Defrost cycle skipped on slave 3 during the sequential defrost stage due to missing conditions for longer than dT1 + tdc + dt + 1 minute (parameters of the master)	Defrost not performed, visual indication only	Check the conditions of the unit and if necessary, check parameter dT1	A	No
96	Sequential defrost skipped on slave 4 alarm	Defrost cycle skipped on slave 4 during the sequential defrost stage due to missing conditions for longer than dT1 + tdc + dt + 1 minute (parameters of the master)	Defrost not performed, visual indication only	Check the conditions of the unit and if necessary, check parameter dT1	A	No
97	Sequential defrost skipped on slave 5 alarm	Defrost cycle skipped on slave 5 during the sequential defrost stage due to missing conditions for longer than dT1 + tdc + dt + 1 minute (parameters of the master)	Defrost not performed, visual indication only	Check the conditions of the unit and if necessary, check parameter dT1	A	No

ID	Description	Cause	Impact	Resolution	Reset (*)	Relay
98	Sequential defrost skipped on slave 6 alarm	Defrost cycle skipped on slave 6 during the sequential defrost stage due to missing conditions for longer than $dT1 + tdc + dt + 1$ minute (parameters of the master)	Defrost not performed, visual indication only	Check the conditions of the unit and if necessary, check parameter dT1	A	No
99	Sequential defrost skipped on slave 7 alarm	Defrost cycle skipped on slave 7 during the sequential defrost stage due to missing conditions for longer than $dT1 + tdc + dt + 1$ minute (parameters of the master)	Defrost not performed, visual indication only	Check the conditions of the unit and if necessary, check parameter dT1	A	No
100	Sequential defrost skipped on slave 8 alarm	Defrost cycle skipped on slave 8 during the sequential defrost stage due to missing conditions for longer than $dT1 + tdc + dt + 1$ minute (parameters of the master)	Defrost not performed, visual indication only	Check the conditions of the unit and if necessary, check parameter dT1	A	No
101	Sequential defrost skipped on slave 9 alarm	Defrost cycle skipped on slave 9 during the sequential defrost stage due to missing conditions for longer than $dT1 + tdc + dt + 1$ minute (parameters of the master)	Defrost not performed, visual indication only	Check the conditions of the unit and if necessary, check parameter dT1	A	No
102	Synchronised defrost alarm skipped	Synchronised defrost skipped due to missing conditions of all the slave devices for longer than $dT1 + tdc + dt + 1$ minute (parameters of the master)	Defrost not performed, visual indication only	Check the conditions of the units and if necessary, check parameter dT1	A	No
103	General alarm 1	Alarm from alarm 1 general function	Visual indication only	Check the configuration parameters in the GEF - ALF group	A	No
104	General alarm 2	Alarm from alarm 2 general function	Visual indication only	Check the configuration parameters in the GEF - ALF group	A	No
105	Slave unit general offline	At least one slave unit is offline	Visual indication only	Check the connection of the master/slave line or the parameters of the NET unit	A	No
106	General alarm on slave unit	At least one slave unit has a serious alarm	Visual indication only	Check the slave unit in alarm state and check the alarm in progress	A	No
107	Sequential defrost skipped on slave unit general alarm	At least one slave unit has skipped the sequential defrost	Visual indication only	Check the conditions of the unit and if necessary, check parameter dT1	A	No

ID	Description	Cause	Impact	Resolution	Reset (*)	Relay
108	Smart Defrost Error Alarm	The Smart Defrost failed to complete the sampling phase for a consecutive number of times equal to the parameters 2x 3Sd + Sd6 or the safety defrost was triggered for a higher number of times Sd3 in a shorter time than Sd2	Visual indication only for 24 hours	Check: <ul style="list-style-type: none"> the state of the cold room and the positioning of the end defrost probe the Smart Defrost function parameters <p>To re-enable the Smart Defrost function, the electronic control must be restarted.</p>	A	No
109	EVD2 Offline Alarm	Possible incorrect connection or disconnection of the EVD2 driver	Unable to regulate overheating, resulting in circuit 2 being stopped	Check the EVD2 driver connection and its address and baud rate parameters	A	Yes
110	EVD3 Offline Alarm	Possible incorrect connection or disconnection of the EVD3 driver	Unable to regulate overheating, resulting in circuit 3 stop	Check the EVD3 driver connection and its address and baud rate parameters	A	Yes
111	Probe S1 EVD2 Alarm	<ul style="list-style-type: none"> BPL2 probe faulty or with measured values outside the operating ranges Faulty or disconnected sensor 	Unable to regulate overheating, resulting in circuit 2 being stopped	Check wiring and integrity of pressure probe BPL2 and replace if necessary	A	No
112	S2 Probe Alarm EVD2	<ul style="list-style-type: none"> Value measured outside the operating ranges Faulty or disconnected sensor 	Visual indication only	Check wiring and integrity of the probe and replace it if necessary	A	No
113	Low Overheating Protection EVD2	<ul style="list-style-type: none"> Overheating too low in circuit 2, below threshold P7 for longer than P9 Overheating too low in circuit 2, below threshold P7 for longer than P9 	Increased valve closure intensity. The more the overheating falls below the threshold, the more the valve will close. The LowSH threshold must be less than or equal to the overheating setpoint. The low overheating integral time indicates the intensity of the reaction: the lower it is, the greater the intensity of the reaction.	Check that the compressor, the thermostatic valve and the low pressure and suction temperature transducers function properly. Check parameters P7, P8, P9 .	A	No
114	Low temperature protection Evaporation EVD2	Evaporation temperature too low in circuit 2, below threshold PL1 for longer than PL3	Increased valve opening intensity. The further the temperature drops below the threshold, the greater the valve opening intensity will be. The integral time indicates the intensity of the action: the lower it is, the greater the intensity.	Check that the thermostatic valve and evaporator fans function properly. Check for ice on the evaporator coil. Check parameters PL1, PL2, and PL3 .	A	No

ID	Description	Cause	Impact	Resolution	Reset (*)	Relay
115	High temperature protection Evaporation EVD2	Evaporation temperature too high in circuit 2, above threshold PM1 for longer than PM3	Controlled closing of the electronic valve resulting in increased overheating. The protection will therefore have a moderate reaction that tends to limit the increase in evaporation temperature, keeping it below the operating threshold, trying to increase the overheating as little as possible.	Cooling demand too high or check that the compressor and thermostatic valve function properly. Check parameters PM1 , PM2 , and PM3 .	A	No
116	Low temperature alarm Suction EVD2	Low suction temperature in circuit 2	Visual indication only		A	No
117	Emergency Close Alarm EVD2	Power failure and valve closed in Emergency due to power supply from an external source (Ultra-cap or UPS)	Interruption of EVD2 valve regulation	Check the power supply of the circuit board	A	No
118	S1 Probe Alarm EVD3	<ul style="list-style-type: none"> BPL3 probe faulty or with measured values outside the operating ranges Faulty or disconnected sensor 	Unable to regulate overheating, resulting in circuit 3 stop	Check wiring and integrity of pressure probe BPL3 and replace if necessary	A	No
119	S2 Probe Alarm EVD3	<ul style="list-style-type: none"> Value measured outside the operating ranges Faulty or disconnected sensor 	Visual indication only	Check wiring and integrity of the probe and replace it if necessary	A	No
120	Low Overheating Protection EVD3	Overheating too low in circuit 3, below threshold P7 for longer than P9	Increased valve closing intensity: the more the overheating falls below the threshold, the greater the valve closing intensity. The LowSH threshold must be less than or equal to the overheating set-point. The low overheating integral time indicates the intensity of the reaction: the lower it is, the greater the intensity of the reaction.	Check that the compressor, the thermostatic valve and the low pressure and suction temperature transducers function properly. Check parameters P7 , P8 , P9 .	A	No
121	Low temperature protection Evaporation EVD3	Evaporation temperature too low in circuit 3, below threshold PL1 for longer than PL3	Increased valve opening intensity. The further the temperature drops below the threshold, the greater the valve opening intensity will be. The integral time indicates the intensity of the action: the lower it is, the greater the intensity.	Check that the thermostatic valve and evaporator fans function properly. Check for ice on the evaporator coil. Check parameters PL1 , PL2 , and PL3 .	A	No

ID	Description	Cause	Impact	Resolution	Reset (*)	Relay
122	High temperature protection Evaporation EVD3	Evaporation temperature too high in circuit 3, above threshold PM1 for longer than PM3	Controlled closing of the electronic valve resulting in increased overheating. The protection will therefore have a moderate reaction that tends to limit the increase in evaporation temperature, keeping it below the operating threshold, trying to increase the overheating as little as possible.	Cooling demand too high or check that the compressor and thermostatic valve function properly. Check parameters PM1 , PM2 , and PM3 .	A	No
123	Low temperature alarm Suction EVD3	Low suction temperature in circuit 3	Visual indication only		A	No
124	Emergency Close Alarm EVD3	Power failure and valve closed in Emergency due to power supply from an external source (Ultra-cap or UPS)	Interruption of EVD3 valve regulation	Check the power supply of the circuit board.	A	No

11. Appendix

This section includes the following topics:

11.1 Decommissioning	86
11.2 Technical features	88
11.3 Attachments	92
Conformity	92
11.4 Time zones	92

11.1 Decommissioning

11.1.1 Required skills



11.1.2 Safety



Always wear protective goggles, footwear, protective gloves and tight-fitting clothes.

DANGER!

Explosion/Burn. Presence of flammable gas. During installation, adopt all the precautions required by legislation in force.

Crushing. Always use lifting equipment and accessories of adequate capacity for the load to be lifted and follow the lifting warnings given in this instruction manual.

Falling from above. Always use adequate means and accessories. Provide safe access to the installation area. Follow the warnings given in this instruction manual.

Electrocution. Always use adequate means and accessories. Follow the warnings given in this instruction manual.

Cut or abrasion. Wear the personal protective equipment.

11.1.3 Warnings

Polluting materials. Environmental contamination.



Disposal of polluting materials according to DIRECTIVE 2012/19/EU (WEEE) and It.Legislative Decree 49/2014 on waste electrical and electronic equipment:

- Do not throw away the packaging of your equipment but sort the materials according to local waste disposal regulations.
- This equipment must not be disposed of in municipal waste but must be disposed of as separate collection. Contact the Waste Electrical and Electronic Equipment (WEEE) collection centres in your area or return it to the vendor when purchasing equivalent new equipment.
- The symbol on the side indicates that the equipment cannot be disposed of as municipal waste.
- Unauthorised or incorrect disposal of the equipment will result in administrative and/or criminal penalties as provided for by the laws in force.

11.1.4 Dismantling the machine

If the machine is to be relocated or has reached the end of its technical and operational life cycle, it must be dismantled. Dismantling procedure

1. Disconnect the energy sources.
2. Disassemble the various components.
3. If necessary, transport and temporarily store the machine in a suitable place.

11.1.5 Scrapping the machine

If the machine has reached the end of its technical and operational life cycle, it must be scrapped. Correct recycling will help prevent potentially adverse consequences for the environment and people.

Scrap the machine by disassembling the various components, separating them according to the material they are made of and take them to the collection facilities indicated by the government or local public bodies.

11.2 Technical features

11.2.1 Dimensions

The dimensions vary with the power and are identified with the dimensions of the condensing fan unit (see "Code legend" on page 2).

11.2.2 Technical data applications in medium temperature

	BEC1301MA05Pxx	BEC1301MA07Pxx	BEC1301MA10Pxx	BEC1301MA20Pxx	BEC2301MA30Pxx	BEC2301MA40Pxx
Size	-	1x300	1x300	2x300	2x300	2x300
Cold room Temperature*	°C	-5°C to 15°C				
Dispersed Thermal Power**	W	1100	1430	1610	2060	2605
Absorption***	W	395	530	570	765	975
	A	2.1	2.9	3.1	4.2	5.3
Maximum Current	A	3.8	5.2	5.6	4.9	7.9
Working Ambient Temperature***	°C	+5°C to +43°C				
Storage Temperature	°C	-25°C to +55°C				
Refrigerant	-	R290				
Refrigerant Charge	Kg	≤ 0.150 per circuit				
GWP	-	3				
Equivalent CO2	t CO2	≤ 0.45				
PS Hp	bar (g)	24				
PS Lp	bar (g)	14.6				
PED Category	-	Article 4.3				
Refrigeration circuit	-	Sealed hermetically				
Expansion unit	-	Mechanical thermostatic valve				
Defrost Type	-	Hot Gas				
Compressor Type	-	Hermetic				
Compressor Displacement	cm3	7.3	10	12.1	16.8	21
Power supply	V/-/Hz	230/1/50				
Industrial plug 2P + E	A	16				
Industrial plug 3P + N + E	A	-				
External protection circuit breaker (curve D)	A	16				
Protection Rating	-	IP 20				
Power cable length	m	2.5				
Cold room light cable length	m	5				
Door micro switch cable length	m	2.5				
BMS cable length	m	5				

	BEC1301MA05Pxx	BEC1301MA07Pxx	BEC1301MA10Pxx	BEC1301MA20Pxx	BEC2301MA30Pxx	BEC2301MA40Pxx
Remote Panel Cable Length	m	5				
Sound pressure (10 m)***	dB(A)	31,5	32,0	31,7	31,5	35,7
Condenser-fan number and diameter	-	1x300				
Condenser air flow rate	m ³ /h	1100				
Evaporator-fan number and diameter	-	1x300				
Evaporator air flow rate	m ³ /h	750				
Evaporator air throw	m	3				
Machine dimensions (Width x Depth x Height)	mm	700 x 1150 x 416				
Total gross weight	Kg	85	86	86	86	120
Total net weight (without packaging)	Kg	64	65	65	65	90
						930 x 1275 x 441

	BEC2302MA50Pxx	BEC2302MA60Pxx	BEC2302MA70Pxx	BEC2353MA80Pxx	BEC2353MA90Pxx
Size	-	2x300	2x350		
Cold room Temperature*	°C	-5°C to 15°C			
Dispersed Thermal Power **	W	4125	4820	5750	7455
	W	1475	1790	2240	2920
Absorption ***	A	8 (230/1/50)	9,7 (230/1/50)	12,2 (230/1/50)	5,3
	A	2,8 (400/3/50)	3,3 (400/1/50)	4,2 (400/3/50)	6,5
Maximum Current	A	9,6 (230/1/50)	14,8 (230/1/50)	19,2 (230/1/50)	10,1
	A	4,3 (400/3/50)	6,9 (230/1/50)	9,1 (400/3/50)	12,3
Working Ambient Temperature***	°C	+5°C to +48°C			
Storage Temperature	°C	-25°C to +55°C			
Refrigerant	-	R290			
Refrigerant Charge	Kg	≤ 0.150 per circuit			
GWP	-	3			
Equivalent CO2	t CO2	≤ 0.9			
PSHp	bar (g)	24			
PSLp	bar (g)	14.6			
PED Category	-	Article 4.3			
Refrigeration circuit	-	Sealed hermetically			
Expansion unit	-	Mechanical thermostatic valve			
Defrost Type	-	Hot Gas			
Compressor Type	-	Hermetic			
Compressor Displacement	cm ³	2 x 16.8	2 x 21	2 x 27.8	3 x 21
Power supply	V/-/Hz	230/1/50 or 400/3/50			
Industrial plug 2P + E	A	16			
Industrial plug 3P + N + E	A	-			
External protection circuit breaker (curve D)	A	16			

	BEC2302MA50Pxx	BEC2302MA60Pxx	BEC2302MA70Pxx	BEC2353MA80Pxx	BEC2353MA90Pxx
Protection Rating	IP 20				
Power cable length	2,5				
Cold room light cable length	5				
Door micro switch cable length	2,5				
BMS cable length	2,5				
Remote Panel Cable Length	5				
Sound pressure (10 m)****	34,5	36,8	38,2	38,1	39,6
Condenser-fan number and diameter	2x300				
Condenser air flow rate	2300				
Evaporator-fan number and diameter	3x200				
Evaporator air flow rate	1150				
Evaporator air throw	4				
Machine dimensions (Width x Depth x Height)	930 x 1275 x 441				
Total gross weight	140	140	154	216	237
Total net weight (without packaging)	110	110	124	170	191

Note (*): values measured at ambient temperature = 32 °C and cold room temperature NT = 0 °C LT = -20 °C.

Note ()**: values measured at condensing temperature = 50 °C and evaporating temperature NT = -10 °C LT = -30 °C.

Note (*)**: with cold room temperature = +15°C the maximum ambient temperature is 38°C.

Note (**)**: the sound pressure levels derive from the sound power level. Conjecturing a hemispherical measuring surface, in free field, without effects of detectable reflections and taking the omnidirectional source into account. The machine to be measured is considered to be placed on the ground with the floor as the only reflective surface.

11.2.3 Technical data applications in low temperature

Size	BEC1301LA10Pxx	BEC1301LA20Pxx	BEC2301LA30Pxx	BEC2302LA40Pxx	BEC2302LA50Pxx	BEC2302LA60Pxx	BEC2353LA70Pxx	BEC2353LA80Pxx
	1x300		2x300		2x350			
Cold room Temperature	-25°C to -5°C							
Dispersed Thermal Power*	1340	1795	2225	2960	3595	4130	5580	6390
Absorption**	590	810	1030	1230	1560	1900	2575	3085
	3,2	4,4	5,6	6,7 (230/1/50)	8,5 (230/1/50)	10,3 (230/1/50)	4,6	5,6
Maximum Current	3,7	7,8	9,9	11,8 (230/1/50)	15,4 (230/1/50)	18,8 (230/1/50)	10,4	12,1
				5,4 (400/3/50)	7,2 (400/3/50)	8,9 (400/3/50)		
Working Ambient Temperature***	+5°C to +43°C							
Storage Temperature	-25°C to +55°C							
Refrigerant	R290							
Refrigerant Charge	≤ 0.150 per circuit							
GWP	3							

	BEC1301LA10Pxx	BEC1301LA20Pxx	BEC2301LA30Pxx	BEC2302LA40Pxx	BEC2302LA50Pxx	BEC2302LA60Pxx	BEC2353LA70Pxx	BEC2353LA80Pxx
Equivalent CO2		≤ 0.45			≤ 0.9			≤ 1,35
PS Hp				24				
PS Lp				14.6				
PED Category				Article 4.3				
Refrigeration circuit				Sealed hermetically				
Expansion unit				Mechanical thermostatic valve				
Defrost Type				Hot Gas				
Compressor Type				Hermetic				
Compressor Displacement	18.7	27.8	33.4	2 x 21	2 x 27.8	2 x 33.4	3 x 27.8	3 x 33.4
Power supply		230/1/50		230/1/50 or 400/3/50			400/3/50	
Industrial plug 2P + E			16					
Industrial plug 3P + N + E						16		
External protection circuit breaker (curve D)				16				
Protection Rating				IP 20				
Power cable length				2.5				
Cold room light cable length				5				
Door micro switch cable length				2.5				
Door heater cable length		2.5				5		
Remote Panel Cable Length				5				
BMS cable length				2.5				
Sound pressure (10 m)****	31.4	32.9	35.3	34.7	35.9	36.1	37.0	37.3
Condenser-fan number and diameter		1x300		2x300				2x350
Condenser air flow rate		1100	2450		2300			4800
Evaporator-fan number and diameter		1x300		2x300				3x300
Evaporator air flow rate		750	1300		1150			2300
Evaporator air throw		3	4.5		4			5
Machine dimensions (Width x Depth x Height)		700 x 1150 x 416		930 x 1275 x 441				1420 x 1300 x 491
Total gross weight	87	94	128	141	155	155	238	238
Total net weight (without packaging)	66	73	98	111	125	125	192	192

Note (*): values measured at ambient temperature = 32 °C and cold room temperature NT = 0 °C LT = -20 °C.

Note (**): values measured at condensing temperature = 50 °C and evaporating temperature NT = -10 °C LT = -30 °C.

Note (***): with cold room temperature = +15°C the maximum ambient temperature is 38°C.

Note (****): the sound pressure levels derive from the sound power level. Conjecturing a hemispherical measuring surface, in free field, without effects of detectable reflections and taking the omnidirectional source into account. The machine to be measured is considered to be placed on the ground with the floor as the only reflective surface.

11.3 Attachments

11.3.1 Documents attached to the manual

- Declaration of conformity
- Electrical diagram of the packaged unit
- Refrigerating diagram

Conformity

Declaration of conformity

Conformity 

Directives List of Directives for which the product is declared to be conforming:

- 2014/68/EU (Pressure Equipment Directive)
- 2014/35/EU (Low Voltage Directive)
- EMC 2014/30/EU (Electromagnetic Compatibility Directive)
- 2006/42/EC (Machinery Directive)
- RED 2014/53/EU (Radio Equipment Directive)

Conformity 

Directives List of Directives for which the product is declared to be conforming:

- UK S.I. 2016 No. 1105 Pressure Equipment (Safety) Regulations
- UK S.I. 2016 No. 1101 Electrical Equipment (Safety) Regulations
- UK S.I. 2016 No. 1091 Electromagnetic Compatibility Regulations
- UK S.I. 2008 No. 1597 Supply of Machinery (Safety) Regulations
- UK S.I. 2017 No. 1206 Radio Equipment Regulations

Note: the original declaration of conformity accompanies the machine.

11.4 Time zones

11.4.1 Time zones table

Time zone	Territory
UTC -12:00	Baker Island, Howland Island
UTC -11:00	Jarvis Island, Midway Atoll, Niue, Palmyra, American Samoa, Kingman Reef
UTC -10:00	Johnston Atoll, Cook Islands, French Polynesia (Society Islands including Tahiti Islands, Tuamotu Islands, Tubuai Islands), United States of America (Hawaii), United States of America (Aleutian Islands of Alaska)*
UTC -9:00	French Polynesia (Gambier Islands), United States of America (Alaska*)
UTC -8:00	Clipperton, Canada (British Columbia*, Yukon*), Mexico (Baja California State*), Pitcairn Islands, United States of America (California*, Idaho (northern)*, Nevada* (excluding West Wendover), Oregon (excluding Malheur County)*, Washington State*)
UTC -7:00	Canada (Alberta*, Northwest Territories*, Nunavut (mountains)*), Mexico (Baja California Sur, Chihuahua, Nayarit, Sinaloa, Sonora*), United States of America (Arizona (Navajo state follows the daylight saving time), Colorado*, Idaho (southern)*, Montana*, Nebraska (west)*, Nevada (West Wendover), New Mexico*, North Dakota (west)*, Oregon (Malheur County)*, South Dakota (west)*, Texas* (west), Utah*, Wyoming*)
UTC -6:00	Mexico (Mexico City, Cancún, Yucatán, Chiapas and other states not mentioned)*, Belize, Canada (Manitoba*, Nunavut (Southampton Island), Nunavut (central)*, Ontario (west)*, Saskatchewan), Costa Rica, Ecuador (Galapagos Islands), El Salvador, Guatemala, Honduras, Nicaragua, United States of America (Alabama*, Arkansas*, Illinois*, Indiana*, Iowa*, Florida (west)*, Kansas*, Kentucky (west)*, Louisiana*, Minnesota*, Mississippi*, Missouri*, Nebraska (east)*, North Dakota*, Oklahoma*, South Dakota (east)*, Tennessee (central and west)*, Texas* (central and east), Wisconsin*)

Time zone	Territory
UTC -5:00	Bahamas, Canada (East Nunavut*, Ontario*, Quebec*), Chile (Easter Island), Colombia, Cuba*, Ecuador, Jamaica, Haiti, Cayman Islands, Turks and Caicos Islands*, Panama, Peru, United States of America (Connecticut*, Delaware*, District of Columbia*, Florida (east and central)*, Georgia*, Indiana (most of the state), Kentucky (east and central)*, Maine*, Maryland*, Massachusetts*, Michigan*, New Hampshire*, New Jersey*, New York*, North Carolina*, Ohio*, Pennsylvania*, Rhode Island*, South Carolina*, Tennessee (east)*, Vermont*, Virginia*, West Virginia*)
UTC -4:00	Anguilla, Antigua and Barbuda, Bermuda, Bolivia, Brazil (Amazonas, Mato Grosso*, Mato Grosso do Sul*, Pará (western), Rondônia, Roraima), Dutch Caribbean, Chile (except Easter Island and Magellan and Chilean Antarctica), Canada (Labrador*, New Brunswick*, Nova Scotia*, Prince Edward Island*), Dominica, Grenada, Guadeloupe, Guyana, Virgin Islands, Martinique, Montserrat, Paraguay*, Puerto Rico, Dominican Republic, Saint Kitts and Nevis, Saint Vincent and the Grenadines, Saint Lucia, Trinidad and Tobago, Venezuela
UTC -3:00	Argentina, Brazil (Alagoas, Amapá, Bahia*, Ceará, Distrito Federal*, Espírito Santo*, Goiás*, Maranhão, Minas Gerais*, Pará, Paraíba, Paraná*, Pernambuco, Piauí, Rio de Janeiro*, Rio Grande do Norte, Rio Grande do Sul*, Santa Catarina*, São Paulo*, Sergipe, Tocantins*), Chile (Region of Magellan and Chilean Antarctica), Falkland Islands, Greenland, French Guiana*, Saint-Pierre and Miquelon*, Suriname, Uruguay
UTC -2:00	Brazil (Fernando de Noronha), United Kingdom (South Georgia)
UTC -1:00	Cape Verde, Azores*
UTC +0:00 Universal time coordinated	Burkina Faso, Canary Islands* (Spain), Ivory Coast, Gambia, Ghana, Guinea, Guinea-Bissau, Ireland*, Iceland, Faroe Islands*, Liberia, Mali, Mauritania, North Pole, Portugal*, United Kingdom*, Sant'Elena, São Tomé and Príncipe, Senegal, Sierra Leone, Togo
UTC +1:00	Albania*, Andorra*, Angola, Austria*, Belgium*, Benin, Bosnia and Herzegovina*, Cameroon, Chad, Vatican City*, Croatia*, Denmark*, France*, Gabon, Germany*, Gibraltar*, Equatorial Guinea, Italy*, Svalbard and Jan Mayen Islands*, Libya, Liechtenstein*, Luxembourg*, North Macedonia*, Malta*, Morocco, Principality of Monaco*, Montenegro*, Niger, Nigeria, Norway*, Netherlands*, Poland*, Czech Republic*, Central African Republic, Republic of Congo, Democratic Republic of Congo (Kinshasa, Bandundu, Central Congo Province, Equator Province), San Marino*, Serbia*, Slovakia*, Slovenia*, Spain*, Sweden*, Switzerland*, Tunisia*, Hungary*
UTC +2:00	Botswana, Bulgaria*, Burundi, Cyprus* (including Northern Cyprus), Egypt*, Estonia*, Finland*, Jordan*, Greece*, Israel*, Latvia*, Lesotho, Lebanon*, Lithuania*, Malawi, Moldova*, Mozambique, Namibia, Palestine*, Democratic Republic of Congo (Western Kasai, Eastern Kasai, Katanga, North Kivu, South Kivu, Maniema, Eastern Province), Romania*, Russia (Zone 1*, including Kaliningrad), Rwanda, Syria*, South Africa, Sudan, Swaziland, Ukraine*, Zambia, Zimbabwe
UTC +3:00	Saudi Arabia, Bahrain, Belarus*, Comoros, Eritrea, Ethiopia, Djibouti, Iraq*, Kenya, Kuwait, Madagascar, Mayotte, Qatar, Russia (Zone 2*, includes Moscow and St. Petersburg; this time zone also applies to all Russia railways), Somalia, South Sudan, Tanzania, Turkey*, Uganda, Yemen
UTC +4:00	Armenia, Azerbaijan, United Arab Emirates, Georgia, Mauritius*, Oman, Reunion, Russia (Zone 3*), Seychelles
UTC +5:00	Kazakhstan (West)*, Maldives, Pakistan, Russia (Zone 4*, includes Ekaterinburg and Perm'), Tajikistan, Turkmenistan, Uzbekistan
UTC +6:00	Bangladesh, Bhutan, (eastern) Kazakhstan, Kyrgyzstan, Russia (Zone 5*, includes Omsk)
UTC +7:00	Cambodia, Indonesia (western), Christmas Island (Australia), Laos, Russia (Zone 6*, includes Novosibirsk, Kemerovo, Krasnoyarsk, Kyzyl), Thailand, Vietnam
UTC +8:00	Australia (Western Australia), Brunei, China (mainland), Philippines, Hong Kong, Indonesia (central), Macao, Malaysia, Mongolia, Russia (Zone 7*), Singapore, Taiwan Please note that all of China has the same time, which makes this time zone exceptionally wide. At the western end of China the sun reaches its zenith at 3pm, at the eastern end at 11am.
UTC +9:00	South Korea (KST – Korean Standard Time), North Korea (NKST – North Korean Standard Time), Japan (JST – Japanese Standard Time), Indonesia (eastern), Palau, Russia (Zone 8*, includes Yakutsk), Timor East
UTC +10:00	The United States has officially designated this time zone as Chamorro Standard Time. , Australia (Australian Capital Territory*, New South Wales* (except Broken Hill), Queensland, Victoria*, Tasmania*), Guam, Northern Mariana Islands, Papua New Guinea, Russia (Zone 9*, includes Vladivostok), Federated States of Micronesia (Yap and Chuuk)

Time zone	Territory
UTC +11:00	Solomon Islands, New Caledonia, Russia (Zone 10*), Federated States of Micronesia (Kosrae and Pohnpei), Vanuatu
UTC +12:00	Fiji*, Wake Island, Marshall Islands, Nauru, New Zealand (Aotearoa)*, Antarctica, Russia (Zone 11), Tuvalu, Wallis and Futuna
UTC +13:00	Fiji*, Wake Island, Marshall Islands, Nauru, New Zealand (Aotearoa)*, Antarctica, Russia (Zone 11), Tuvalu, Wallis and Futuna
UTC +14:00	Kiribati (Line Islands or Southern Sporades)

RIVACOLD
MASTERING COLD



RIVACOLD srl
Fraz. Montecchio - via Sicilia, 7
61022 Vallefoglia (PU)
Italy

www.rivacold.com
info@rivacold.com
Tel. +39 0721 919911
Fax +39 0721 490015

BEST CM R290
© 2023 RIVACOLD srl